



WHAT'S INSIDE:



Rod Hall's President report  
PAGE 3



Calendar of Events  
PAGE 6



AGM Presidents Report.  
PAGE 4

July 2011

# The Bulletin

The Official Publication of the Ballarat Light Car Club



# OMG !! 23 TESTS \$100 !!

We have approval from CAMS for another sub event for the *Winter Classic*. This weekend, we are offering an opportunity people to enter just the driving tests for the 3 days. See pages 23 to 25

**Ripping It Up at the SHOWGROUNDS and MORE - ALL RIGHT !!!**



**Congratulations to our newest CLUBMAN - Mark Hunter**



## News in Brief

**Winter Classic time again**  
One of the best events of the year is the Classic. It all begins this Friday night at the show grounds so don't go out to the club rooms because you will be on your own and missing out on all the action. If you like to be close to the action

rip in and grab yourself a hi vis vest and get amongst it as an official, as good as getting a free vip ticket to be sure.

### Committee Members needed

You may not be aware but the

BLCC is running low on committee members there are still 3 vacancies and this means that possibly for yet another year those members who remain are in needs of some assistance. If you ever thought of becoming a committee member sign up now because we need to

share the load.

### ThePetition

As you know the committee prepared a petition. This took the form of a cover letter and petition forms copies included in the last issue. The aim of is to raise with

*Continued page 9*



# Committee 2011 - 12



## **President - Rod Hall**

Phone: 5331 3546 Mob: 0438 313 546 blccpresident@hotmail.com  
Events Secretary rod.hall@ballarat.edu.au



## **Vice - President - Noel Peers**

AH: 5330 2295 Mob: 0439 652 325 bennett@ncable.net.au  
(Minutes taker - Property / Equipment Officer)



## **Treasurer - Clare Bennett**

AH: 5330 2295 Mob: 0439 652 325 bennett@ncable.net.au



## **Secretary - Wayne Sanders**

Mob: 0412 713023 AH: 5334 2330 w.sanders@optusnet.com.au



## **Membership Secretary Stacey Noonan**

Mob: 0417 163 193 staceynoonan@hotmail.com



## **House Chairman - Steve Ezzy**

Mob: 0400 160 158 AH: 5339 4821 stvezzy@hotmail.com



## **Media Liason - Les Noonan**

Mob: 0410 524 139 AH: 5331 6148



## **Sports Sub Chair - Barney Haddon**

Mob: 0437 167 790 AH: 5335 5112 barno4@bigpond.net.au  
(Hill Climb Panel - Motorsport Complex)

## **Motorsport Complex - Shane Williams**

Mob: AH:

## **Non Committee Positions**

**State Council - Ian Brain - 0418 518 088**

**Officials Licences - Damien Faulkner 0458 566 619**

**CH Plates - AX Series - Chris Hall - 5342 4397**

**MK Series - Ben McKee -**

**Keys Keeper - Rod Robson -**

**VCRS - John Wellford**

**CAMS - Permits Administrator - David Milne - 9593 7732**

## **The Bulletin**

*A monthly newsletter of the  
Ballarat Light Car Club*

**Editor:** Steve Ezzy

**E-Mail:** blcceditor@hotmail.com

**Mob:** 0400 160 158

**Contribute:** Contributions can be e-mailed or posted to 1014 Ring Road Ballarat

**Deadline:** 7 pm Thursday, 8 days prior to monthly club meeting.

## **Website Info**



<http://blcc.net.au/>

**Webmaster:** Wayne Sleep

**AH:** 5339 4890

**Mobile:** 0419 031 712

**E-Mail:** blccwebmaster@hotmail.com

# Presidents Report August 2011

## President's Report August 2011

Greetings one and all. This is my inaugural President's report. First thing I need to say is a big thank you to Noel Peers for the last 2 years during which he has been our President. I also need to thank Les Noonan for being our Vice President. Thank you also to Ian Brain who has retired from committee for all the hard he did whilst on committee. Ian has kindly offered to remain our Delegate at State Council. Having only been in this role for 2 weeks I can assure you speaking from my initial experience that Noel and Les have been busy over the past 2 years. I had 4 meetings in the first week and could have gone to a 5<sup>th</sup> if I'd wanted to which was a baptism of fire as they say. I much prefer the water one I have to admit Noel and Les's leadership and diligence to the task of running our great club has been much appreciated.

For those who haven't heard the make up of your new committee most of the scary positions have been filled. We still have 3 positions on committee that are vacant. We will endeavour to fill these in the next little while by "seconding" people. If you are remotely interested please make it known to one of us. A few other positions are currently awaiting approval of the incumbent who was previously doing the role. The Sports Sub needs a minute secretary which is a fairly easy but important role. This sub committee is not overly formal and features a lot of talk about cars and events surprise surprise.

Motorsport in the past

month has seen Ben McKee direct Rd 3 of our Motorkhana series which was won by Greg Pitt with his good wife Sharon in second place with Leon Pegg rounding out the top 3. Congratulations to the outright stars and all the class winners who are also stars in their own right. Seems that Sharon's win the other week wasn't a flash in the pan. Not to put the pressure on but we might have a "Lady" series winner!! (also without being sexist that is)

Our AGM was a great night for those attended to hear Bob Watson launch his book "Phillip Island to Fangio" The History of the Light Car Club of Australia. Bob's speech was very enlightening expounding on where some of our history has come from. He was able to tell us some of the significant milestones and initiatives that our forbears made and took. Interestingly I can now answer a question that I have previously been unable to answer on numerous occasions. This question being what is a Light Car? This is a perfectly reasonable question given we are the Ballarat Light Car Club. The answer being: I'll let you read the book or ask someone who was there. If you didn't come you missed out on a good feed and some good yarns as Stapo rekindled a few more infamous bits of Bob's motorsport history. Congratulations to Mark Hunter who was the deserved recipient of our annual Clubman Award at the AGM.

Coming up we have the Winter Classic Trial and Tour. The organising committee have been working real hard over the



recent short time pulling this event together. If you can help out with running any of the driving tests or the touring sections please speak to any of the organising committee. Friday Night will once again see us all at the showgrounds where the drivers will have 3 maybe 4 goes at the test the Marmo boys set up in there. Please don't come along to the club rooms expecting a monthly meeting but instead come along to the showgrounds don a High Viz Vest, sign on as an official and give us a hand with running the test or sell some raffle tickets for a ride in a VRC Champion's Rally Car or another significant Rally Car so we can raise some much needed funds for the SES. We will also have a captive audience who can sign our petition. Saturday morning will see us return to Victoria Park after a few years off. To **make** this venue work safely we will need all hands on deck so we can keep the course secure from spectators wanting to get too close to the action. The cars are due to start some time shortly after 7:30am so its an early start but should be worth it. Numerous other test venues then kick into action a bit later over the next 2 days. Please if you can help at any time no matter how short sing out and we'll certainly give you a job.

At present the entry list for the Winter Classic is very light on so if you are interested in entering please do as it is shaping up to be a

great event. I am now also at liberty to advise that in order to swell the field a bit we have secured CAMS permission to allow extras to enter at a cheaper fee (\$50 per day or \$100 for all 3 days) to just do the driving tests. You don't even have to do them all. You even get to have squirt in Vicky Park! You only get to do the tests without all the trimmings of food, hats etc but should be great fun and good value. If this interests you please get on the blower to Clare Bennett who is the event secretary.

We also have Round 4 of our Cec Jackman Motorkhana series being directed by Ash Findlay and Keith McElroy fast approaching followed by the rescheduled Barney's Double Banger Autocross. Make sure

you enter to keep these events viable.

Steve Ezzy, Wayne Sanders and I had occasion to go along to the Ballarat Golf Club to hear the Council's position on the New West Employment Zone that is planned in the immediate environ near the Ballarat Airport that is also putting significant and real pressure on our continued use of the Autocross Track. We now have some further information on timelines but were also given the opportunity to give some feed back and suggestions. Somebody wrote an essay and I probably don't need to tell you who. We will keep you posted as this process continues to rollout. Please keep on the petition trail getting as many signatures as you can.

Its also good news that a couple of our members Sleepy and Barney (could be dwarfs) who have had unplanned visits to the hospital over the last week or so are on the mend. We also hope that a certain bearded fella is getting on OK down Geelong way.

That's probably enough from me for now, hope to see you at the Winter Classic next weekend or out at the club in the near future.

Rod Hall

---

## AGM Presidents Annual Report

### 2010-2011 PRESIDENTS REPORT.

It is 7.57 pm the 29<sup>th</sup> July 2011.  
Time to make a start.

I'm Noel Peers the current President and on behalf of the Ballarat Light Car Club would like to extend a very warm welcome to all our friends and associates gathered here to commemorate our 20<sup>th</sup> AGM. This is my second year as President and it gives me great pleasure to present my report for 2010-2011.

Firstly the Club welcomes our invited guests, Garry and Karen Grant, John Emery, Ben Manning (CAMS), Ian Home, Rhonda Coghlan, Trevor Ryan, Peter Stapleton, and our guest speaker Mr Bob Watson.

It is with regret that we have received

apologies from Sharon Knight MP, Catherine King MP, David Morgan (CAMS CEO) Mayor and Councillors of Ballarat, Jack Ellis, Kerry Bruty, Frank Devine, Paul Duncalf, and Chris Hall.

This financial year has been another busy one for the Club.

Four Motorkhanas to make a series, four Autocrosses to make a series, we also ran two other Autocross events, Barney's Double Banger, and the Geordie Fawcett Memorial Autocross as well as two Khanacross events.

We ran a round of the Victorian State Hillclimb Championship at Mt Leura and some members assisted Ararat Car Club in running their two rounds.

The Club also ran our major event The Winter Classic Rally and Tour, and our three way event, Coghlan's Carnival.

The Club was fairly heavily

involved in assisting Garry Grant's, Ballarat Festival of Motoring, the X-Trial, George Derrick Trial, and the Uplands Stages. We ran a very successful Come and Try and Training Day with round one of the Autocross series.

All up the B.L.C.C. has been involved in running or assisting with at least 20 events over the past year, not a bad effort considering that there is only 52 weekends in a year. Outside the competition side of things a lot of regular participants found time to again assist in our major fundraiser the delivering of phone books over a two to three week period in March/ April raising much needed funds for the Club at the rate of 36 cents per delivery. A thank you night is yet to be organised.

Congratulations must go to all competitors and winners of our Series and championships held this

year.

**CLUB DRIVERS CHAMPION  
BEN MCKEE**

**CEC JACKMAN MEMORIAL  
AWARD (MOTORKHANA  
SERIES)**

**MICK GOOSSENS**

**AUTOCROSS SERIES  
BEN MCKEE**

**CLUB TRIALS CHAMPIONSHIP  
SIMON ELLIS**

**B.J. NICHOLSON NAVIGATORS  
AGGREGATE  
IAN ELLIS**

**WINTER CLASSIC (RALLY)  
CHRIS HALL and NOEL PEERS  
WINTER CLASSIC (TOUR)  
MICHAEL PRATT and  
MICHAEL MOORE**

**COGHLAN'S CARNIVAL  
BEN MCKEE**

**GEORDIE FAWCETT  
MEMORIAL AUTOCROSS  
DAMIAN FAULKNER**

Achieving plenty of success at state and National levels was Mark Fawcett in Rallying, Glenn Latter and Steve Grinstead in Hillclimbs.

I'd like now to thank individually our hard working Committee. (Could committee please stand.) Vice President Les Noonan, Treasurer Clare Bennett, Membership Secretary Wayne Sanders, House Chairman, Motorsport Complex Manager, and unofficial Club Historian Barney Haddon, Sports Sub Committee Chair and CAMS event Secretary Rod Hall, Bulletin Editor Steve Ezzy, (with assistance from Wayne Sleep), general all round assistant Stacey Noonan, and CAMS State Delegate Ian Brain (absent). Shane Williams our grader driver who due to health reasons has assisted when able. That's only 10 members including myself. Angela Ruyg was seconded onto Committee in February/March, but due to a conflict of interest with work had to resign. Thanks to all Committee members for your time and effort throughout the year and a bigger thank you to returning members, Les Noonan, Barney Haddon, and Steve Ezzy. Ian Brain is standing down but will remain our CAMS delegate. Thanks Ian for that. We start the new financial year with 3 vacancies. Thanks also to all members of Sports Sub Committee Rod Hall, Barney Haddon, Dave Marmo, Wayne

Sleep, Steve Richards, Ben McKee, Ben Davis, and any others who assisted.

Thanks to all those who have officiated in whatever capacity as the events can't run without you. Some major thank you's, Mum, same as last year for her ongoing support and running the Normans Street Truck Stop and Cafe, Chris Hall, and Barney Haddon for advice and help, as both were past Presidents. My workmate Richard Pearson for working with me and swapping weekends around so that I could attend nearly every event that the B.L.C.C. has been involved in. Thanks must go again to Barney for the organisation of this years trophies.

Hope I haven't bored you too much, thanks for listening and I'm very proud to have had the privilege to guide the Club over the last 2 years. Noel Peers.

B.L.C.C. President.

**POST SCRIPT.**

The Clubman award goes to a member who has contributed over and above the norm to the Club for the past year. I'd like now to call on our guest speaker Mr Bob Watson to present this years award. This goes to Mr Mark Hunter.

---

## Treasurers Report August 2011



Please keep up the good effort with direct payments My full annual report is on page 10

Clare Bennett Treasurer 2010-2011 Mob: 0439 652 325 E: bennett@ncable.net.au

Still looking for an apprentice to learn the fine art of book keeping for the club

Pay your membership from anywhere!!  
Ballarat Light Car  
Club banking details  
BSB No: 633-000 Ac-  
count No: 141857458

# VCRS

## Temporary Change To Series Rules for Scoring

The VCRS for 2011 was originally calendared with 5 rounds.

Two of those rounds have failed to run due to lack of entries and force Majeure respectively.

In the interests of conducting a contested series in 2011, the VCRS committee voted at the committee meeting held on 19-08-2011 to

Temporarily change the series rules for 2011 to allow for the series to be scored on the basis of "heats" instead of "events"

The following 2011 rallies shall count as the following number of heats:

- EGS/Bog-a-Duck: 1 heat
- Nissan Nightmoves: 1 heat

- Marysville Stages: 2 Heats (1 daylight, 1 night).

Marysville Stages competitors who DNF in the first heat may be able to rejoin the second heat, subject to approval of the Chief Scrutineer and Clerk of Course.

Details of the rule changes will be posted as an addendum to the series rules.

(Issued 20-08-2011)

The following changes to the series rules for 2011 only, were approved at the VCRS committee meeting of 19-08-2011.

1. For 2011 only, the VCRS Series Rules shall be altered by replacing the word "event" with the word "heat" in the following clauses:

- 2.1, 2.2,
- 4.1.8
- 5.1, 5.2, 5.3 and 5.4

2. For 2011 only, the following events shall be scored as one heat each.

- Bog-a-Duck/EGS,
- Nissan Nightmoves.

3. For 2011 only, the following event shall be scored as two heats:

- Marysville Stages, with the "daylight" stages being Heat 1 and the "night" stages being Heat 2.

Michael Seidler  
Hon Sec VCRS 2011

These documents will soon be available on Vicrally VCRS page.

---

## Club Permit Information

### PROCESS FOR OBTAINING CLUB PERMITS FOR VEHICLES.

The following is the current process for getting your vehicle onto the Club Permit system.

First of all the vehicle must be a minimum of 25 years old (to the month) and in roadworthy condition. Current registration is not necessary. The owner MUST present a current Club membership card and MUST remain a member in order to continue to use the vehicle.

When ready contact the Clubs designated officer to arrange processing.(Details below.)

The vehicle is to be checked for suitability for use on Club Plates either with a roadworthy certificate or by myself as the designated officer. A nominal fee is charged for the check.

Once the paperwork is completed you

go to Vic Roads for processing.

You have a choice of either 45 or 90 day permits, and it's a log book system which you are responsible for.

After you receive your plates and paperwork from Vic Roads (usually up to 3 weeks,) it is YOUR responsibility to notify me with the expiry date and plate details. The Club is responsible for keeping accurate records. At present that's me. Therefore, if you sell the vehicle, smash it, remove it from the road, don't renew your membership, or change Clubs, you MUST notify me and in some cases hand back the plates to Vic Roads.

### RENEWING YOUR CLUB PERMIT.

When your permit is nearing its expiry date you will automatically receive a renewal from Vic Roads which you then must get signed by me. At present the Club is asking a fee of \$5 for all renewals to help cover the

cost of being a member of A.O.M.C. payable on me signing off your permit.

PLEASE REMEMBER THAT YOU ARE RESPONSIBLE TO MAINTAIN YOUR VEHICLE IN A ROADWORTHY STATE. SOME VEHICLES THAT HAVEN'T BEEN SEEN OUT AT THE CLUB FOR A WHILE MAY REQUIRE A CHECK TO BE CARRIED OUT PRIOR TO RENEWAL.

Chris Hall.

B.L.C.C. Club Permit officer.  
53424397 or 0438094684. Leave details if need be. (Limited phone coverage at home.)

# Your Club Get Involved

## Editorial

Well, here we are in a new episode of our clubs history. A new President and reshuffled committee we set of once again, only this time there would seem to be a tumultuous period heading our way because of the changes that would seem to afoot with our council preparing for the future growth of industry and residences. Of course this will eventually be at the expense of our track but lets hope there is time to find a new home before all is lost. Speaking of which if you do have any ideas or you have a piece of idle land you want to give away please don't hesitate to contact us.

I made no secret of the fact that I had presidential ambitions but in the end I have to say that I am pleased to have come second to our new president elect,

Rod who I think with his vast experience and knowledge will be an excellent leader though what we expect to be a difficult period. Noel Peers has stayed on in the position of Vice in order to assist Rod though his settling in period. Noel has indicated that he will step aside in one year to allow a new prospect to serve as Vice in the following year. Clare Bennett, who I feel has been overlooked and even undervalued in some respects is standing down as treasurer in one year. When she goes she will need to be replaced. This is not a position that a person can be expected to simply take over. To this end we would love for someone to begin some informal training to alleviate some of the stress that I am sure will occur when her impending retirement occurs.

As is always the case at this time of year, there has been a reshuffle of the committee

and one of the changes is to the Membership Secretary. Stacey will, like others before her, be enduring a settling in period so if you need to deal with her please be understanding of her situation. On that note I would like to ask if any members would have the time of expertise to assist in the creation of an on-line club data base, perhaps using a web site, Drop box or cloud technology or maybe you know someone please contact us. Helping out the club does not always mean waving a flag or manning a radio!

Wayne the Luxo barge driving mechanic is now our club secretary, a position that has been vacant for some time, good luck Wayne.

Please check the committee list on page two for other changes.

## Sport Sub Committee Notes

August Bulletin Sports Sub Precis

Barney is going to approach a Mens Shed Group about producing our trophy boards so we can catch up with trophies we haven't handed out.

Thank-you to Greg Pitt, Shane Williams and Barney Haddon for the recent grading of the Autocross Track prior to Barney's Double Banger Autocross.

Barney's Double Banger was way under subscribed and the SCC is at a bit of a loss as to why. Please tell us if you know. Was it the Wednesday night close of entries, winter chilly weather ? Please tell us.

Rich River Revisited Trial was attended by our AGM speaker Bob Watson along with Steve Richards and Fred Lakerink. Steve and Fred finished 6<sup>th</sup> outright.

The AGM a good night enjoyed by all those who attended. The rest of you missed out.

Motorkhana Rd 3 in hand with Ben McKee.

Motorkhana Rd 4 in hand with Ash Findlay and Keith McElroy

Winter Classic bubbling along with Vince McDonald and Mark Bennett at the helm. A coordinator for the tests is needed if any-one feels so inclined.

Seemore Stages on the calendar for 3/09/2011 has been cancelled due to DSE not allowing the usage of the Wombat Forest because it is too wet.

Sunday 18<sup>th</sup> September Rob Roy Hillclimb VHC RD now also a BLCC CDC round. CDC7.

The 2011 VCRS in trouble after cancellation of Cooper. Now only 3 events available which doesn't constitute a series. Not much we can do about it. Cooper tried to run on 3 different dates so there was no 3<sup>rd</sup> time lucky.

BLCC CTS is still viable as a series with 4/5 events being run so far.

Participation level very low.

Lightened 4WD would still be allocated to the 4WD class. When rules are looked at perhaps it is time to look at splitting the 4WD to standard & modified. Float this idea in bulletin perhaps.

Investigate quarry area near Creswick re Complex relocation.



# autoparts

PROFESSIONALS  
BALLARAT



Lightforce Lights from \$359  
Narva 225's from \$350



NEW 2011  
Range of Bell  
Helmets  
from \$499



NEW for 2011 Indy 3  
Boots \$199!



RPM Club Gloves \$89  
Mechanics Gloves from \$29.95



Hydraulic Handbrake \$249



Don't forget Auto Parts Professionals gives discount to BLCC's Members!

Call in and see Nathan and David, for there huge range of stock, 7 days a week, for friendly advise and great prices, supporting the Ballarat light car club for 15 years!

Auto Parts Professionals, 9 Doveton St Nth, Ballarat, 53329333

## News in Brief *continued*

the council the need for them to ensure the future of the BLCC. You can help by obtaining signatures of support on the petition, and returning it to us in the enclosed prepaid envelope before August 31 2011. Thank you for your assistance and support. Have you made any progress, did you remember?

### Club Historian

The committee is calling for expressions of interest from persons interested in becoming the club historian.

### Direct Payments A Success

Several members and hopefully many more have taken advantage of the method of paying directly into the BLCC account . So give it a go, and pay for membership or event payments and make everything simpler for you and for the treasurer.

### Winter Classic on FaceBook

Check out the FaceBook page for the Winter Classic Trial & Tour, be sure to click the like button.

<http://www.facebook.com/pages/Winter-Classic-Trial-and-Tour/191208827601526>

# ROBSON GLASS

Established over 98 years

Shop Fronts



Broken Glass Replacement



24hr Emergency Service



Cut To Size Glass & Glazing



Insurance Work



Lead Lighting



Mirrors



Safety & Sound Proof Glass



Glass Splashbacks



Shower Screens



Double Glazing



W J ROBSON & SONS PTY LTD  
**5332 2078 MBL 0418 508 429**  
 After Hours 5341 3898 or 5339 4664  
 Cnr Maun Rd & Humffray St Ballarat

## Club Scrutineers

### Notice to Bulletin Advertisers

If you wish to place an advertisement, please consult the Treasurer, **Clair Bennett** (5330 2295 or 0439 652 325) who will arrange an invoice and pass the request to the Editor, **Steve Ezy**, for inclusion in the appropriate issues.

Please see the table below for the Annual Fee for Advertising

Size	Annual Fee (\$)	1 Month Fee (\$)
Full Page	220	22
Half Page	143	14.30
Third Page	119	11.90
Quarter page	99	9.90
Sixth Page	89	8.90
Eighth page	79	7.90

Member Small adverts of the Buy, swap & Sell type will continue to be **Free**

Chris Hall	Grade 2	5342 4397 0438 094 684
Noel Peers	Grade 3	5341 8124
Darren Wythe	Grade 3	0448 417 506
Ben McKee	Grade 3	5336 1172 0418 313 695
Wayne Webb	Grade 3	5334 7698

**Liability Disclaimer** – All material in this magazine represents the opinions of the authors and does not carry any endorsement by the Editor or the Committee, Ballarat Light Car Club has no official connection with any public or commercial organisation and it does not provide product recommendations. Names of commercial products mentioned in this magazine are registered names and trademarks of their owners. Copyright Notice – Material in this magazine may be copied by any other club without fee or written permission provided that the copyright rests with the Ballarat Light Car Club. The copies are not to be used for commercial advantage and the origins of the material and this permission to copy are acknowledged in the reprinted item. The Nissan Car Club-Australia is acknowledged as the source for the wording of this Disclaimer.

# AGM Treasurers Report 2011

Welcome everyone to the 2011 AGM. It is with pleasure I present the financial for the year.

The figures presented at the AGM are supplied from McMaster Accounting Services but as yet have been signed off by the Auditors Molloy, Orr & Rowan. They are just waiting on bank authorisation to look at our accounts for finalisation.

2010-11 has seen the club realise a surplus of \$7234. The year before saw a surplus of \$10857.

The first event was the Trivia Night held on July 2 which raised about \$3000 for the Club. The next major event was the Winter Classic Trial & Tour 2010. We encouraged some of our younger members to get involved in the Event Management and I have to say Samara Bennett did a fantastic job as Clerk of Course (not biased at all!). Stacey Noonan and Lewis Lakerink also put their hand up to help and it is probably no coincidence that all three have parents in the BLCC. Thanks also goes to the mentors who worked with them and showed their encouragement and support. (Fred, Les, Dave, Barney, Rod just to name a few.) Around \$3300 was raised from that event. This was down on 2009 due to a drop in entry numbers but it also funded the purchase of 30 new reflective witches hats for use in other club events.

This past year we have reduced numbers of competitors for the Autocross and Morkhana Series. We still managed to come

out ahead by \$916 overall. The Autocross figures show quite a difference between the last 2 years but there was about \$3000 belonging to the Autocross series from 2009 that was not banked until after the end of the financial year. In reality there is a difference of about \$900 between the two years.

Challenge of Clubs, Begonia and Stapos Khanacross did not run in 2010/2011 financial year.

Barney's Double Banger was popular as was Cogs Carnival and the Geordie Fawcett Memorial was one of the best Christmas events in a while!

The Victorian Hillclimb Rnd 3 was held at Mt Leura in April this year, and was again a success. Congratulations to the directing crew and the team that manned the Hill. \$1957 was raised from this event.

A couple of extra special events came our way with the Grand Prix promotion in Sturt St and the Festival of Motoring at Easter. The City of Ballarat donated \$1000 to the Club for assistance in officiating in Sturt St and \$1000 was also given to the Club courtesy of Gary Grant and the promotions team for the Festival of Motoring Reenactment of the Grand Prix at the Airport.

The Phone Book Delivery fund-raiser was back with \$2780.74 being raised. Thanks to the phone book volunteers and Noel for his perseverance under some trying conditions. It seems a well oiled system has been upgraded to make it complicated and about four times the work! By the way

we still owe you guys a Pie Night!

Infrastructure work has again been active this year. Rainfall has assisted the usual track maintenance. We have been able to purchase a new stove for the Club rooms and a new hot water service that actually provides hot water to the bathrooms for the first time!

We have some significant challenges ahead with the probable loss of our track in the not too distant future. This is most likely the biggest milestone for the Club since 1991 when the BLCC became an entity in its own right. We will need the support of all our members to meet that challenge.

Thanks to all the members and friends who contribute to the Club through membership, competition and volunteering at events. Without you we would not be here.

Finally, to my fellow committee members. Much work goes on behind the scenes that most people don't know about and I personally thank you all for your efforts. Noel, thanks for your dedication and support to me as Treasurer during your term as President. You are truly an asset to this Club.

Cheers,

Clare Bennett

Treasurer 2010-2011  
Ballarat Light Car Club

## CAMS Upcoming Training

Wednesday 24th August	Bronze Fire & Rescue Training Course	CAMS
Monday 12th September	Bronze Stewards Course	CAMS
Thursday 27th October	Club Chief Training Course	CAMS
Monday 14th November	Event Assessor Training Course	CAMS



«AUGUST 26, 27 AND 28»

# WINTER CLASSIC TRIAL & TOUR

more information and expressions of interest to: [bennett@ncable.net.au](mailto:bennett@ncable.net.au)



# 2011 AUG INFORMATION

PRESENTED BY BALLARAT LIGHT CAR CLUB



**NOW IN ITS 14TH YEAR**  
**BITUMEN ONLY EVENT!**

The Ballarat Light Car Club's Winter Classic Rally & Tour returns for 2011. The weekend starts with a BBQ dinner on Friday night and a run under lights to kick the event off at the Showgrounds. Saturday you have your choice of, Tour or the TRE and then the first of our driving tests Saturday evening has us sharing tales of a different style, Sunday brings challenges of a different style, concluding at our historic clubrooms.

[HTTP://WINTERCLASSIC.BLCC.NET.AU/](http://winterclassic.blcc.net.au/)

## E-mail Notifications.

**A** new e-mail notification system has been implemented on our site to simplify the process of keeping members and other interested parties informed of goings on in the club.

Sign up to receive event updates and announcements from Ballarat Light Car Club about upcoming events and activities. E-mail announcements will be sent out occasionally about website-related activities and new website features.

Note: this feature is not in place of the electronic send out of the club newsletter. And all recipients of the bulletin should feel free to sign up for notifications.



## Proposed Members Business Register

I was pondering how I was going to find someone to complete the removal of a huge amount of Wisteria from my side fence. I considered the phone book for a moment and as I did so I thought about who in the BLCC might know someone from the club who knew someone? I was then prompted to think about the amount of useful information that could be collated into a list of useful business / skills / hobbies that people have, do or run.

To this end I thought I might put my idea out there, I will collect a list of members (proposed to me) of people who are likely to be useful to other members. I do not propose that there be any discounts or freebies just a list of people and their field of expertise.

So, if you make stickers, weld up roll cages, are an expert in suspension, electronics, gardening, office supplies, sell bolts, make trailers, are a retired business man willing to offer advice, are an expert in IT or lay cement than you should be on this list.

If you would like to be on this list (Name, Number and field) then SMS or Phone me Steve Ezzy 0400 160 158 or email blcceditor@hotmail.com

**M**embers listed below have nominated themselves as being willing to assist fellow members

**Peter Ellis** (Driving Ambition) Driver Training Specialist to Individuals and Business - Mobile 0419 002 007 Tel. (03) 5334 3144



# Mechanica Industries

design·create·repair·salvage

- Mechanical engineering
- Automotive maintenance & repairs
- Machine shop
- On-site maintenance

*If its metal, we can design it, create it, repair it or salvage it.  
At Mechanica Industries, we love machines!*

Mechanica Industries are located at **12 Paddys Drive Delacombe 3356**

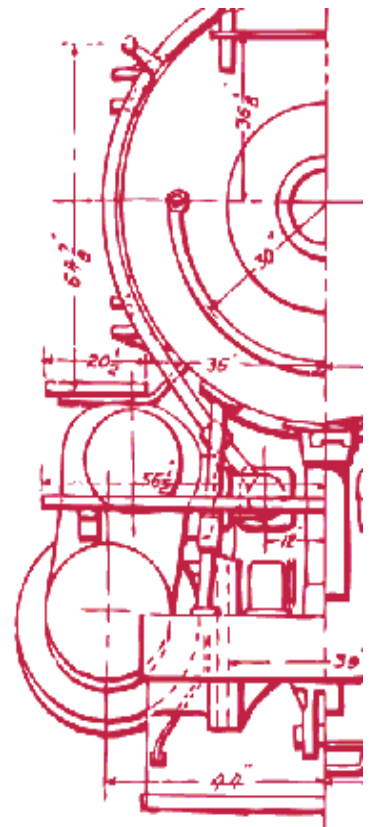

[www.mechanicaindustries.com.au](http://www.mechanicaindustries.com.au)

# 5335 7251

# VCRS Notes - John Welford

Word has just come through from the VCRS committee meeting in Melbourne. Thanks John Welford for going down and forwarding this info back so we can get it into the Bulletin. As you may have heard the VCRS was in danger of not constituting as series this year because too many events have been cancelled for numerous different reasons.

To prevent this from happening the VCRS committee have decided that the Marysville Stages which is yet to be run, which has a daylight division and night division will be scored as 2 heats whilst all the other events that have already happened will be considered to be one heat.. This will then give the right number of heats to constitute a series. This rule will only apply for 2011

In terms of our BLCC Club Trials Championship which the Marysville Stages was part there of it means that the overall event with the 2 heats combined will be used to determine your points for the CTC. This means competitors will need to complete both heats or both the day and night divisions to score points for the BLCC CTC.

## Event Calendar



### ■ August

#### Friday 26th

Winter Classic Rally and Tour  
No Club Meeting

#### Saturday 27th

Winter Classic Rally and Tour  
Ivans Folly

#### Sunday 28th

Winter Classic Rally and Tour  
Victorian Hillclimb Championship  
Round 7, Haunted Hills

### ■ September

#### Saturday 3rd

Mt Porpunkah Rally Spring  
The Lions Rally

#### Saturday 10th

Mafeking Mahem

#### Sunday 11th

BLCC, Motorkhana 4 CDC6  
Geelong Motorkhana R1

#### Saturday 17th

Marysville Stages, VCRS Round 4, CTS6

#### Sunday 18th

CSA Wheels Victorian Hillclimb  
Championship Round 8 Rob Roy CDC7  
Geelong AX/KX R7 - Autocross

#### Sunday 25th

Barney's Double Banger Autocross

#### Friday 30th

BLCC Club Meeting

### ■ October

#### Friday 7th

Bathurst 1000

#### Saturday 8th

Seemore stages round 2

#### Sunday 9th

Bathurst 1000  
Proposed BBQ and Bathurst day at  
BLCC Clubrooms. (register your interest  
bathurst2011@blcc.net.au)

#### Saturday 15th

Akademos VRC4

#### Sunday 16th

Sandown Sprints CDC8  
Geelong AX/KX R8 - khanacross

#### Friday 28th

BLCC Club Meeting

#### Saturday 29th

Bagshot Rallysprint

### ■ November

#### Saturday 5th

Coghlan's Carnival

#### Sunday 6th

Coghlan's Carnival  
Geelong Motorkhana R2

#### Saturday 12th

Rally Victoria

#### Sunday 20th

Reserve Date for BLCC Autocross and  
Series  
Geelong AX/KX R9 - Autocross

#### Friday 25th

BLCC Club Meeting

#### Saturday 26th

Alpine Rally

### ■ December

#### Saturday/Sunday 3rd/4th

Ararat One Tree Hillclimb

#### Sunday 11th

Geordie Fawcett Memorial Autocross,  
Xmas Breakup  
Geelong Come & try khanacross



OUTRIGHT			Test 1		Test 2		Test 3		Test 4		Test 5		Test 6				
Rnd 3 2011																	
Competitor	Vehicle	Class	Time	Pens	Time	Pens	Time	Pens	Time	Pens	Time	Pens	Time	Pens	Total Time	OR Result	Class Result
Greg Pitt	Civic	C	32.30		51.04		44.39		59.26		62.20		54.73		303.92	1	1
Sharon Pitt	Crx	L	31.57		51.25		43.42		55.84		62.71		63.58	H	308.37	2	1
Leon Pegg	Gemini	H	35.73		50.97		44.11		60.58		63.74		57.53		312.66	3	1
Dave Jowett	Pulsar	A	33.12		53.03		43.78		62.16		69.37		52.50		313.96	4	1
Mick Goossens	Subaru	F	34.96		51.44		48.34		63.13		62.94		60.91		321.72	5	1
Paul Gladman	Pulsar	A	33.31		52.23		43.57		62.60		69.64		61.72		323.07	6	2
Robert Dekker	Laser	A	37.72		52.57		41.71		66.14		65.04		66.23		329.41	7	2
Mark Hunter	Colt	C	40.10		57.90		45.96		62.82		69.62		60.94		337.34	8	3
Craig Hunter	Colt	J2	47.04		51.28		44.03		68.48		66.70		63.46		340.99	9	4
Ash Wilson	Camira	J3	55.36		62.85		54.88		63.96		68.10		64.27		369.42	10	1
Rhys Lane	Civic	J2	42.95		59.95		49.41		67.47		84.08		91.07		394.93	11	2
Peter Jowett	Pulsar	J1	39.01		61.54		57.71		68.18		77.20		68.43		372.07	12	3
Brayden Hammond	Falcon	J2	52.26	H	61.49		51.59		73.62		74.47		72.43		385.86	13	4
Heath Salter	Camira	J1	89.19	H	71.89		57.05		75.80		99.01		141.41		534.35	14	1
Marc Salter	Laser	A	99.19		81.89		62.71		85.80		109.01		151.41		590.01	15	4
Slowest Time			89.19		71.89		57.71		75.80		99.01		141.41		535.01		
Slowest Time + 5			94.19		76.89		62.71		80.80		104.01		146.41				
Slowest Time + 10			99.19		81.89		67.71		85.80		109.01		151.41				
Fastest Time			31.57		50.97		41.71		55.84		62.20		52.50		294.79		
CLASSES			Test 1		Test 2		Test 3		Test 4		Test 5		Test 6				
Competitor	Vehicle	Class	Time	Pens	Time	Pens	Time	Pens	Time	Pens	Time	Pens	Time	Pens	Total Time	OR Result	Class Result
<b>UP TO 1800 STD</b>																	
Dave Jowett	Pulsar	A	33.12		53.03		43.78		62.16		69.37		52.50		313.96	4	1
Paul Gladman	Pulsar	A	33.31		52.23		43.57		62.60		69.64		61.72		323.07	6	2
Robert Dekker	Laser	A	37.72		52.57		41.71		66.14		65.04		66.23		329.41	7	3
Marc Salter	Laser	A	99.19	DNS	81.89	DNS	62.71	DNF	85.80	DNS	109.01	DNS	151.41	DNS	590.01	15	4
<b>UP TO 1800 MOD</b>																	
Greg Pitt	Honda	C	32.30		51.04		44.39		59.26		62.20		54.73		303.92	1	1
Mark Hunter	Colt	C	40.10		57.90		45.96		62.82		69.62		60.94		337.34	8	2
<b>4WD</b>																	
Mick Goossens	Subaru	F	34.96		51.44		48.34		63.13		62.94		60.91		321.72	5	1
<b>Historic</b>																	
Leon Pegg	Gemini	H	35.73		50.97		44.11		60.58		63.74		57.53		312.66	3	1
<b>Juniors 12&amp;13yrs</b>																	
Peter Jowett	Pulsar	J1	39.01		61.54		57.71		68.18		77.20		68.43		372.07	12	1
Heath Salter	Camira	J1	89.19		71.89		57.05		75.80		99.01		141.41		534.35	14	2
<b>Juniors 14&amp;15yrs</b>																	
Craig Hunter	Bluebird	J2	47.04		51.28		44.03		68.48		66.70		63.46		340.99	9	1
Rys Lane	Civic	J2	42.95		59.95		49.41		67.47		84.08		91.07		394.93	11	2
Brayden Hammond	Falcon	J2	52.26		61.49		51.59		73.62		74.47		72.43		385.86	13	3
<b>Juniors 16&amp;17yrs</b>																	
Ash Wilson	Camira	J3	55.36		62.85		54.88		63.96		68.10		64.27		369.42	10	1
<b>Ladies</b>																	
Sharon Pitt	Honda CRX	L	31.57		51.25		43.42		55.84		62.71		63.58		308.37	2	1



One of those who are at the heart of our club, Rhonda Parkinson. Best wishes on regaining your health our thoughts are with you.

**House & Home**

- House Renovations & repairs
- Plasterboard Hanging & Finishing
- Floor & Wall Tiling
- Concreting, Shed slabs, path's, driveways
- Tree felling & lopping
- Any size job
- Quality work
- Upholstery coming soon!

**Signs & Graphics**

- Race & Rally Signage
- Magnetic Signs
- Boards, Banners & A Frames
- Shop front & Business signage

**Vehicles**

- Competition car preparation, Panel beating & Spray painting
- Welded Rollcages to Cams specs
- General welding(Cert. 8G) & fabrication.

**Wayne & Angela Webb**  
 10 Frawleys Rd, Leigh Creek, 3352  
 PH:53 347698 OR MOB:0438 347 698  
 Email: webballtrades@westnet.com.au

## Sport Sub Committee

Rod Hall (Chair) Barney Haddon, Ben McKee, Darren Wythe (Rally Liason), Damian Faulkner, Steven Richards, Wayne Sleep, David Marmo, Peter Marmo, Ben Davis.

Meetings: Wednesday night immediately prior to monthly committee meeting.

## Leaving the complex after Scrutineering

If a competition vehicle needs to leave the motor sport complex, you must remove your numbers so the Police or Vic Roads don't nab you. Also the vehicle needs to be re-presented for scrutiny upon its return before continuing competition.

## For Sale

**S**lightly used 15 inch rally tyres and some alloy rims to suit a Datsun  
 Please contact Chris Hall on 53424397 or 0438094684.

## CTC Series Competitors: Early Entry

This year, the general lack of rallies is causing events to fill up fast. To make sure you get a run, you will need to enter quickly when entries open.

The Sport Sub Committee has decided not to remove events from the CTC Series if someone misses out, unless they have entered within 10 days of entries opening for that event and been refused

<i>Club Driving Instructors</i>					
John	Bourke	Wayne	Drew	Rod	Prosser
Richard	Gay	Gary	Harrowfield	Barney	Haddon
Mick	Goossens	Engles	Leoncini	Peter	Ellis
Les	Listen	Simon	Ellis	Darren	Wythe
Darren	Everett	Ben	McKee	Steve	Richards
Damian	Faulkner	Russell	McKenzie	Mark	Fawcett
Ben	Fawcett	Steve	Wilson	Chris	Hall
Keith	McElroy	Ben	Davis	Mark	Hunter

# Membership



## WELCOME NEW MEMBERS

New members for this month are;  
Lucas Gregg, introduced by Daniel Kierce so i would think Lucas will see some action in the Left hand seat of the Datto. Graeme Akers. Graeme has a Falcon Coupe of which he is duly proud (only driven on sunny days). The car may not see competition but Graeme is quite keen to help around the club.  
Leon Harris, introduced by Jason Beckerleg and David Marmo, drives a Laser and Escort.  
The Members extend a warm welcome to you all.

Well, another AGM has come and gone. I thought Bob Watson gave a very interesting talk on the history of the LCCA and judging by some of the things that he mentioned in passing there a lot more stories that could be told, given the time and place.  
After the AGM the committee has a reshuffle, so we welcome Rod Hall as the new President, i will be taking the role of Secretary and i will be handing over the Membership duties to Stacey Noonan. I have been toiling away every night this week to get every one entered on the Database and all the cards sent out so that things are



in order for the hand over to Stacey.  
As i hand over to Stacey i will say that i have enjoyed meeting the new members and assisting them with their first steps in the club. Thanks for your support and patience.  
Anyway see you at the Club,  
Regards Wayne.

## 2011 Hillclimb Calendar

**C**alendar for 2011

**Round 7** – VMCI Haunted Hills F8 28th August  
**Round 8** – MGCC 18th September

**A** reminder for all email recipients of this publication, please keep your email address current with the membership secretary.

Wayne Sanders  
Email: w.sanders@optusnet.com.au



Phone:  
AH: 5334 2330  
Mob: 0412 713023

## Getting Social Stay informed join us on FaceBook and Twitter



Ballarat Light Car Club



BallaratLightCC

# CAMS Peter Brock Award

The CAMS Board recently approved a proposal to introduce a new award to the CAMS honours list. This award is the Peter Brock Award, in honour of motor sport legend, the late Peter Brock AM.

The Peter Brock Award will be awarded annually to a driver who has shown similar character to the late Peter Brock AM. The award recognises outstanding driver ability and commitment to the positive endorsement of motor sport within the greater community.

Australia produces some of the best motor sport talent in the world across all motor sport disciplines and this award aims to recognise those competitors whose passion for the sport not only shines through in their outstanding driving ability but also through their positive attitude and commitment to give back to the sport and community.

CAMS is now calling for nominations for this inaugural award for 2011. The details of the award are outlined below:

## Award Description

In honour of motor sport legend, the late Peter Brock AM, this award recognises outstanding driver ability and commitment to the positive endorsement of motor sport within the greater community.

## Award Criteria

A nominee must have demonstrated outstanding driver ability whilst displaying a fair and sportsmanlike attitude, respect for authority, and support, encouragement and motivation of and for their peers, as well as a willingness and capacity to promote the sport in the wider community.

## Award Eligibility

Nominees must be Australian citizens and hold a current CAMS licence at the time of competition;  
All disciplines within the sport are eligible to be considered for this award;  
The Peter Brock Award may not be bestowed on a serving Director of CAMS;  
Whilst there is no age limit, it is likely that the successful candidate would be between the ages of 18-35 years.

CAMS is also pleased to announce the representatives of the newly established Peter Brock Award Selection Committee who will deliberate on nominations and make a recommendation to the Board of CAMS for its approval.

CAMS welcomes Touring Car Champion Craig Lowndes, Australian Rally Champion Coral Taylor, Herald Sun Motoring Editor Paul Gover, James Brock representing the Brock family and Garry Connelly AM, Chairman of the CAMS Honours and Awards Committee.

The Peter Brock Award is open to anyone who would like to nominate, via the nomination form available on the CAMS website. Nominations for the Peter Brock Award close 30 September 2011.

Any queries should be directed to Ashlee English on 03 9593 7720.



# BLCC Income & Expenditure Statement to June 2011

## Ballarat Light Car Club Incorporated Income and Expenditure Statement For the year ended 30 June 2011

	2011	2010
	\$	\$
<b>Income</b>		
Clubroom Hire	1,400	1,105
Door Proceeds	-	760
Annual General Meeting	1,515	2,418
➤ Donations	1,461	5,000
Subscriptions & Nominations	11,711	11,841
CH Plate Registrations	205	313
Special Efforts	6,877	80
Bulletin Advertising	130	-
Bar Takings/ Catering	6,095	5,378
Interest received	2,772	1,050
Profit on sale of property, plant equip.	837	-
Autocross Entries/Sponsors	11,245	4,326
Hill Climb Entries/Sponsors	6,042	7,543
Begonia Rally Entries/Sponsors	-	35,396
Motorkhana Entries/Sponsors	1,026	-
Winter Rally Entries/Sponsors	10,299	19,445
Rally Entries	-	6,364
Khanacross Entries/Sponsors	-	264
Coghlan's Carnival Entries	1,881	1,727
<b>Total Income</b>	<b>63,494</b>	<b>103,009</b>

**Ballarat Light Car Club Incorporated**  
**Income and Expenditure Statement**  
**For the year ended 30 June 2011**

	2011	2010
	\$	\$
<b>Expenses</b>		
Accountancy	2,000	2,000
Annual General Meeting Expenses	1,996	2,166
Audit fees	800	650
Autocross Expenses	6,862	2,735
Bank Fees And Charges	96	78
Begonia Rally Expenses	-	29,152
Bulletin Expenses	2,901	2,300
Cleaning/rubbish removal	968	1,276
C.A.M.S Track Licence	773	-
C.A.M.S. Capitation/ Affiliation	650	632
Coghlan's Carnival Expenses	897	977
Depreciation - plant	5,691	5,466
General expenses	457	298
Heating	2,168	1,878
Hill Climb Expenses	4,085	4,962
Insurance	2,528	2,164
Internet Expenses	-	204
Khanacross Expenses	155	-
Lease payments	653	579
Licences and Permits	212	561
Motorsports Complex	1,400	2,400
Motorkhana Expenses	450	337
Motor Vehicle Expenses	908	1,810
Postage	139	141
Repairs - Plant & Equipment	2,305	1,246
Repairs - Buildings & Improvements	145	1,947
Printing & stationery	480	589
Rally Expenses	(330)	5,039
Rates & land taxes	938	689
Refreshments/ Food	5,319	6,145
Rent on land & buildings	602	585
Special Efforts	1,351	-
Telephone	541	503
Trophies/ Gifts	1,113	1,429
Winter Rally Expenses	7,005	11,215
<b>Total Expenses</b>	<b>56,260</b>	<b>92,152</b>
<b>Profit for Year</b>	<b>7,234</b>	<b>10,857</b>

The accompanying notes form part of these financial statements.

**Ballarat Light Car Club Incorporated**  
**Detailed Balance Sheet As At 30 June 2011**

	Note	2011 \$	2010 \$
<b>Current Assets</b>			
<b>Cash Assets</b>			
Cash At Bank - Bendigo		-	16,851
Cash at Bank - Bendigo CMA		-	54,215
Cash Management - Trading / /c		13,430	-
Term Deposit - 7813		51,496	-
Term Deposit - 7730		15,356	-
Cash on hand		554	3,225
		<u>80,836</u>	<u>74,291</u>
<b>Receivables</b>			
Sundry Debtors		220	80
		<u>220</u>	<u>80</u>
<b>Current Tax Assets</b>			
GST Liability		360	(7)
		<u>360</u>	<u>(7)</u>
<b>Total Current Assets</b>		<u>81,416</u>	<u>74,364</u>
<b>Non-Current Assets</b>			
<b>Property, Plant and Equipment</b>			
Leasehold improvements		26,343	26,343
Less: Accumulated depreciatio		(13,887)	(12,865)
Plant & Equipment		72,854	69,031
Less: Accumulated depreciatio		(48,214)	(44,244)
Motor vehicles		6,400	10,719
Less: Accumulated depreciatio		(2,838)	(5,022)
		<u>40,657</u>	<u>43,962</u>
<b>Total Non-Current Assets</b>		<u>40,657</u>	<u>43,962</u>
<b>Total Assets</b>		<u>122,073</u>	<u>118,325</u>

The accompanying notes form part of these financial statements.

**Ballarat Light Car Club Incorporated**  
**Detailed Balance Sheet As At 30 June 2011**

	Note	2011 \$	2010 \$
<b>Current Liabilities</b>			
<b>Payables</b>			
Unsecured:			
Sundry Creditor & Accruals		7,671	13,060
		<u>7,671</u>	<u>13,060</u>
<b>Provisions</b>			
Autocross Track Repairs		1,760	360
		<u>1,760</u>	<u>360</u>
<b>Other</b>			
Income Received in Advance		5,502	5,000
		<u>5,502</u>	<u>5,000</u>
<b>Total Current Liabilities</b>		<u>14,934</u>	<u>18,421</u>
<b>Total Liabilities</b>		<u>14,934</u>	<u>18,421</u>
<b>Net Assets</b>		<u>107,139</u>	<u>99,905</u>
 <b>Members' Funds</b>			
<b>Reserves</b>			
Member's Accumulated Funds		99,905	89,048
Surplus for Year		7,234	10,857
<b>Total Members' Funds</b>		<u>107,139</u>	<u>99,905</u>

The accompanying notes form part of these financial statements.

**Ballarat Light Car Club Incorporated**  
**Divisional Profit and Loss Statement**  
**For the year ended 30 June 2011**

	MEMBERS & CLUBROOMS	MOTORSPORT	Total
<b>Income</b>			
Clubroom Hire	1,400	-	1,400
Annual General Meeting	1,515	-	1,515
Donations	1,461	-	1,461
Subscriptions & Nominations	11,711	-	11,711
CH Plate Registrations	205	-	205
Special Efforts	6,877	-	6,877
Bulletin Advertising	130	-	130
Bar Takings/ Catering	6,095	-	6,095
Interest received	2,772	-	2,772
Profit on sale of property, plant equip	837	-	837
Autocross Entries/Sponsors	-	11,245	11,245
Hill Climb Entries/Sponsors	-	6,042	6,042
Motorkhana Entries/Sponsors	-	1,026	1,026
Winter Rally Entries/Sponsors	-	10,299	10,299
Coghlan's Carnival Entries	-	1,881	1,881
<b>Total</b>	<b>33,001</b>	<b>30,493</b>	<b>63,494</b>
<b>Expenses</b>			
Accountancy	2,000	-	2,000
Annual General Meeting Expenses	1,996	-	1,996
Audit fees	800	-	800
Autocross Expenses	-	6,862	6,862
Bank Fees And Charges	96	-	96
Bulletin Expenses	2,901	-	2,901
Cleaning/rubbish removal	968	-	968
C.A.M.S Track Licence	-	773	773
C.A.M.S. Capitation/ Affiliation	650	-	650
Coghlan's Carnival Expenses	-	897	897
Depreciation - plant	1,027	4,664	5,691
General expenses	457	-	457
Heating	1,953	216	2,168
Hill Climb Expenses	-	4,085	4,085
Insurance	2,187	341	2,528
Khanacross Expenses	-	155	155
Lease payments	-	653	653
Licences and Permits	212	-	212
Motorsports Complex	-	1,400	1,400
Motorkhana Expenses	-	450	450
M/V car - Fuel & oil	-	908	908
Postage	139	-	139

The accompanying notes form part of these financial statements.

**Ballarat Light Car Club Incorporated**  
**Divisional Profit and Loss Statement**  
**For the year ended 30 June 2011**

	MEMBERS & CLUBROOMS	MOTORSPORT	Total
Plant & Equipment	1,186	1,119	2,305
Building and Improvements	82	64	145
Printing & stationery	480	-	480
Rally Expenses	-	(330)	(330)
Rates & land taxes	623	316	938
Refreshments/ Food	5,319	-	5,319
Rent on land & buildings	602	-	602
Special Efforts	1,351	-	1,351
Telephone	541	-	541
Trophies/ Gifts	1,113	-	1,113
Winter Rally Expenses	-	7,005	7,005
<b>Total</b>	<b>26,683</b>	<b>29,577</b>	<b>56,260</b>
<b>Divisional Profit</b>	<b>6,318</b>	<b>916</b>	<b>7,234</b>

# WCT&T 23 Tests for \$100

We have approval from CAMS for another sub event for the Winter Classic. We are offering an opportunity people to enter just the driving tests for the 3 days.

There is a fee of \$100 for Friday night, Sat and Sunday tests( 3 days) or \$50 per day. This is great value for 23 tests.

This is a Multiclub permit so spread the news as places are limited. We have no issue with officials helping at the tests competing in the event but obviously we don't want to lose your assistance so plan it out!

As it will not be scored against the Trial and Tour competitors it is not compulsory to have a co driver, however it may be an advantage!

Remember you need

A Cams competition license minimum 2S (Driver) Non driver 2NS

To be a member of a car club

Have your car scrutineered Wed night from 5.30pm at Eclipse Motors 1 Albert St Sebastopol To comply with the WCT&T supp regs and further regs

An entry form and the WC supp regs are in this Bulletin. Further will be out Monday just explaining the new sub event to WC full competitors. Scrutiny requirements are in the Supps. Please be aware there are no meals included in this event, however you are welcome to attend the WC dinner Sat night for \$30.00 head. My fax no is in the supp regs and payment can be made by direct credit to the BLCC account or to me as event secretary directly or through the BLCC PO Box 400, Ballarat.

**DISCLAIMER  
EXCLUSION OF LIABILITY, RELEASE AND ASSUMPTION OF RISK  
COMPETITORS AND/OR COMPETING CREWS AND/OR SERVICE CREW  
IN RALLIES**

**For Competitors**

I/We being the competitor/s of the vehicle described on this Entry Form wish to enter that vehicle for the above event.

**For Competitors and competing crew/ and service crew**

I/We being the competitor/s and/or driver and/or co-driver and/or navigator and/or service crew, certify that the particulars on this form are true and correct in every particular, to the best of my/our knowledge and belief.

I/We declare that I/we have read and understood the Supplementary Regulations issued for the event, and agree to be bound by them and the provisions of the National Competition Rules of the Confederation of Australian Motor Sport Limited ("CAMS").

In exchange for being able to attend or participate in the event (including entering the event), I agree:

- to release CAMS and Australian Motor Sport Commission Ltd, promoters, sponsor organisations, land owners and lessees, organisers of the event, their respective servants, officials, representatives and agents (collectively, the "**Associated Entities**") from all liability for my death, personal injury (including burns), psychological trauma, loss or damage (including property damage) ("**harm**") howsoever arising from my participation in or attendance at the event, except to the extent prohibited by law;
- that CAMS and the Associated Entities do not make any warranty, implied or express, that the event services will be provided with due care and skill or that any materials provided in connection with the services will be fit for the purpose for which they are supplied; and
- to attend or participate in the event at my own risk.

I/we acknowledge that:

- the risks associated with attending or participating in the event include the risk that I may suffer harm as a result of:
  - motor vehicles (or parts of them) colliding with other motor vehicles, persons or property;
  - acts of violence and other harmful acts (whether intentional or inadvertent) committed by persons attending or participating in the event; and
  - the failure or unsuitability of facilities (including grand-stands, fences and guard rails) to ensure the safety of persons or property at the event.
- motor sport is dangerous and that accidents causing harm can and do happen and may happen to me.
- the route instructions should not be relied upon exclusively in estimating the degree of severity of any hazard which might be encountered, or the manner in which any section of the road is driven, whether shown in the route instructions or not, and that I/We have been advised to exercise caution in following these route instructions.

I accept the conditions of, and acknowledge the risks arising from, attending or participating in the event and being provided with the event services by CAMS and the Associated Entities.

I/we acknowledge that my/our personal information will be processed in accordance with the CAMS privacy policy which is available from the [www.cams.com.au](http://www.cams.com.au) and where I/we suffer from any injury, sickness or death during the Event, I/we consent to the release by health services of my/our personal health information to an authorised representative of CAMS or the Event who may use it in the preparation and release within and outside Australia of accident or incident information and reports to interested parties for the purposes of accident investigation, accident prevention and safety activities, news services including broadcast services, or for the purposes of processing insurance claims.

I understand that this disclaimer is not intended to exclude any valid claim I may have under the CAMS Personal Insurance Scheme.

Competitor's signature: ..... Date: .....  
Driver/s signature: ..... Date: .....  
Navigator/Co-Driver/s signature: ..... Date: .....

*For persons under the age of 18 years the following parent/guardian consent must be completed.*

**PARENT/ GUARDIAN CONSENT – PERSONS UNDER 18 YEARS OLD**

I ..... of [Address] ..... am the parent/ guardian\* of the above-named ("the minor") who is under 18 years old. I have read this document and understand its contents, including the exclusion of liability and assumption of risk, and have explained the contents to the minor. I consent to the minor attending/ participating in\* the event at his/her own risk.

Signed..... Date.....  
Parent/Guardian\*

\* Delete whichever does not apply



**2011**  
**Ballarat Light Car Club**  
**WINTER CLASSIC ENTRY FORM**



OFFICE USE

**DRIVING TESTS ONLY**  
**Must present for scrutiny Wed 24th August at**  
**Eclipse Motors 1 Albert St from 5.30pm onwards**

Please refer to Supplementary Regulations for the Winter Classic for event requirements

Held under the International Sporting Code of the FIA and the National Competition Rules of CAMS  
 Fee \$100 per COMPETITOR or \$50 PER DAY

Direct credit available to BSB 633 000 Account No: 141857458

**EVENT: Driving Tests only**       FRI    SAT    SUN

**CAR CLUB** \_\_\_\_\_

<b>COMPETITOR (Car Owner)</b>		<b>SPONSOR (must hold CAMS Licence)</b>	
Name _____		CAMS Licence _____	
Address _____		Postcode _____	
Tel (w) _____	Tel (h) _____	Fax _____	Mobile _____
Email address: _____			

<b>DRIVER</b>			
Name _____		Civil Licence _____	CAMS Licence _____
Address _____		Postcode _____	
Tel (w) _____	Tel (h) _____	Fax _____	Mobile _____
Email address: _____			

<b>NAVIGATOR/CO-DRIVER (if participating)</b>			
Name _____		Civil Licence _____	CAMS Licence _____
Address _____		Postcode _____	
Tel (w) _____	Tel (h) _____	Fax _____	Mobile _____
Email address: _____			
Preferred Mailing Address (tick one)		COMPETITOR: <input type="checkbox"/>	DRIVER: <input type="checkbox"/>
		NAVIGATOR: <input type="checkbox"/>	

<b>VEHICLE</b>			
MAKE	MODEL	YEAR	CLASS
COLOUR	BODY TYPE	CAPACITY      cc	CAMS OR CLUB LOG BOOK NO
REG NO	4 WD      Y / N	SCRUTINY REQUEST BALLARAT/REGIONAL	

**PLEASE COMPLETE THE DETAILS AND SIGNATURES REQUIRED OVERLEAF**  
**If you are printing or copying this entry form, please use double-sided printing or copying**

**OFFICE USE ONLY**

Date entry received	Cheque / Money order / Cash	BSB / Cheque No	Account name
Licences checked	Civil <input type="checkbox"/>	Cams Comp <input type="checkbox"/>	Club membership <input type="checkbox"/>



# Renewal of Membership

## Ballarat Light Car Club

Incorporated (Certificate of Incorporation Number A20023019V)  
P.O.Box 400 Ballarat, Vic, 3353

This form is important for any personal information changes please return to club

Membership Number **«Me»**

«Ho «Surname» \_\_\_\_\_ «Given» \_\_\_\_\_

«Street Address» \_\_\_\_\_ «Town» \_\_\_\_\_

«Post» \_\_\_\_\_

Telephones - Private: «Phone Home» \_\_\_\_\_ Business: «Phone Work» \_\_\_\_\_ Mobile: «Phone Mobile» \_\_\_\_\_

Email Address: «EmailAddress» \_\_\_\_\_ DOB: «Birthday» \_\_\_\_\_

desire an **ORDINARY**  **FAMILY**  **ASSOCIATE FAMILY**  **ASSOCIATE PARENT**  **ASSOCIATE COUPLE**   
membership of the Ballarat Light Car Club and agree, if elected, to be bound by the rules and bylaws of the club.  
( mark the applicable category of membership )

### Current Fees ( 01/07/11 )

Category	Nomination	Annual
<b>Ordinary</b>	\$25.00	<b>\$90.00</b>
<b>Family</b>	\$25.00	<b>\$120.00</b> (2 Adults, any number of own Children up to 17y.o)
<b>Associate Family</b>	nil	<b>\$83.00</b> (2 non-competing Adults, 1 competing child )
<b>Associate Parent</b>	nil	<b>\$58.00</b> (Parent/Guardian, 1 Child competing)
<b>Associate Couple</b>	nil	<b>\$50.00</b> (2 non competing adults)

I enclose membership of \$ \_\_\_\_\_ or I have paid via direct deposit to BSB **633 - 000** Acn **141 857 458** (pls include name & member no. )

Occupation / Employer: «Occupation» \_\_\_\_\_

Names of Family Members: Partner: \_\_\_\_\_ Child 1: \_\_\_\_\_ Child 2: \_\_\_\_\_

Child 3: \_\_\_\_\_ Child 4: \_\_\_\_\_

Type of vehicle/s that you will use to compete: Make: \_\_\_\_\_ Model: \_\_\_\_\_

I would like to receive my BULLETIN electronically at my email address above:  or to alternate address \_\_\_\_\_

Signature: \_\_\_\_\_ Date: \_\_\_\_\_

Please return this form with your renewal and enter or change any details as required, so that we can keep our records up to date.



# Application for Membership

## Ballarat Light Car Club

Incorporated (Certificate of Incorporation Number A20023019V)  
P.O.Box 400 Ballarat, Vic, 3353

Dear Sir/Madam

I,   
 Mr \_\_\_\_\_ (Surname) \_\_\_\_\_ (Given Names in Full)  
 Mrs \_\_\_\_\_  
 Miss \_\_\_\_\_  
 Ms \_\_\_\_\_

of \_\_\_\_\_ (Postal Address) \_\_\_\_\_ (Town / Suburb) \_\_\_\_\_ (Post Code)

Telephones - Private: \_\_\_\_\_ Business: \_\_\_\_\_ Mobile: \_\_\_\_\_

Email Address: \_\_\_\_\_ @ \_\_\_\_\_ DOB: \_\_\_\_\_

desire an  ORDINARY  FAMILY  ASSOCIATE FAMILY  ASSOCIATE PARENT  ASSOCIATE COUPLE   
 membership of the Ballarat Light Car Club and agree, if elected, to be bound by the rules and bylaws of the club.  
 ( mark the applicable category of membership )

### Current Fees ( 01/07/11 )

Category	Nomination	Annual
Ordinary	\$25.00	\$90.00
Family	\$25.00	\$120.00 (2 Adults, any number of own Children up to 17y.o)
Associate Family	nil	\$83.00 (2 non-competing Adults, 1 competing child )
Associate Parent	nil	\$58.00 (Parent/Guardian, 1 Child competing)
Associate Couple	nil	\$50.00 (2 non competing adults)

I enclose membership of \$ \_\_\_\_\_ I have paid via direct deposit to BSB 630-000 Acn 141857458 (please include name and member number )

Occupation / Employer: \_\_\_\_\_

Names of Family Members: Partner: \_\_\_\_\_ Child 1: \_\_\_\_\_ Child 2: \_\_\_\_\_

Child 3: \_\_\_\_\_ Child 4: \_\_\_\_\_

Type of vehicle/s that you will use to compete: Make: \_\_\_\_\_ Model: \_\_\_\_\_

I would like to receive my BULLETIN electronically at my email address above: \_\_\_\_\_

Signature: \_\_\_\_\_ Date: \_\_\_\_\_

**Please fill in all details and attach appropriate fees when submitting this form**

We, the undersigned, being members of the Ballarat Light Car Club, wish to recommend acceptance of the above application of the above application for membership. The above named candidate is personally known to us and we believe him/her to be a suitable person to be elected a member of the Ballarat Light Car Club Inc.

Proposer: \_\_\_\_\_ Signature: \_\_\_\_\_ Member No. \_\_\_\_\_

Seconder: \_\_\_\_\_ Signature: \_\_\_\_\_ Member No. \_\_\_\_\_

Office Use Only	
Received: / / 20	
Fees \$.....	
Received	<input type="checkbox"/>
Welcome Letter	<input type="checkbox"/>
Member Number .....	
Completed	<input type="checkbox"/>



If undeliverable return to  
**Ballarat Light Car Club**  
PO Box 400  
Ballarat Vic 3353

**The Bulletin**

Print Post Approved

**PRINT  
POST**  
PP325876/00031

**POSTAGE  
PAID  
AUSTRALIA**

