



WHAT'S INSIDE:



Noel Peers President report
PAGE 3



Calendar of Events
PAGE 6



History Slice.
PAGE 20

July 2011

The Bulletin

The Official Publication of the Ballarat Light Car Club

Phillip Island to Fangio

The History of the Light Car Club of Australia

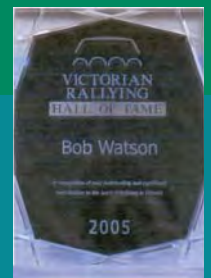

What's a nice car like Holden Kingswood doing in a place like this?

Winning!

**Holden Kingswood
First: Rounds 4 and 5 -
Vic. Rally Championship.
First: Round 4 -
NSW Rally Championship.**

If you've never thought of Kingswood as a rallywinner, think again. Kingswood has just won three of Australia's most grueling trials events... and after the other... Kingswood's wide track road holding, smooth 4-coil ride and positive front-mounted steering turned tough into tame. And it'll do the same for you. Smooth sleek Holden Kingswood. Rugged, reliable Holden Kingswood. Any way you want it, get behind the wheel of a winner at your Holden Dealer now.

Annual General Meeting this Friday 29th July

Annual General Meeting

This year's meeting is a little under subscribed so get in soon and get you tickets. This year, our guest speaker is Bob Watson. Tickets will once again

be available at Frank Devine's car yard in Howitt St for \$38.

Committee Members needed

You may not be aware but the BLCC is running low on committee members there are still 3 vacancies and this means that possibly for

yet another year those members who remain are in needs of some assistance. If you ever thought of becoming a committee member sign up now because we need to share the load

Important Petition

You committee is preparing to

distribute a petition. This will take the form of a cover letter and petition forms., copies included in this issue. The aim of is to raise with the council the need for them to ensure the future of the BLCC. You can help by obtaining signatures of support

Continued page 9



Committee 2010 - 11

The Bulletin

A monthly newsletter of the
Ballarat Light Car Club

Editor: Steve Ezzy
E-Mail: blcceditor@hotmail.com
Mob: 0400 160 158
Contribute: Contributions can be e-mailed or posted to 1014 Ring Road Ballarat
Deadline: 7 pm Thursday, 8 days prior to monthly club meeting.

Website Info



<http://blcc.net.au/>

Webmaster: Wayne Sleep
AH: 5339 4890
Mobile: 0419 031 712
E-Mail: blccwebmaster@hotmail.com

President

Noel Peers
Property Officer
AH: 5341 8124
Mob: 0408 033 895
blccpresident@hotmail.com



Secretary

(Currently vacant)
Mob:
blccsecretary@hotmail.com

Treasurer

Clare Bennett
AH: 5330 2295
Mob: 0439 652 325
bennett@ncable.net.au



Grants Officer

Assistant Media Liaison
Officer
Stacey Noonan
Mob: 0417 163 193
staceynoonan@hotmail.com



Events Secretary

C.A.M.S Liaison
Sport Sub
Committee Chair
Rod Hall
53313546
0438 313 546
rod.hall@ballarat.edu.au



Sports Sub Committee

Ben McGee
Barney Haddon
0437 167 790 / 5335 5112
Damian Faulkner
0407 643 803

CAMS

Permits Administrator
David Milne / 9593 7732

Vice President

State Council Rep
Les Noonan
AH: 5331 6148
Mob: 0410 524 139



Membership Secretary

w.sanders@optusnet.com.au
Wayne Sanders
AH: 5334 2330
Mob: 0412 713023



House Chairman

M/sport Cplx Manager
Assistant Property Officer
Hillclimb Panel Rep
Barney Haddon
AH: 5335 5112
Mob: 0437 167 790
barno4@bigpond.net.au



CAMS State, AASA

Delegate

Ian Brain
Mob: 0418 518 088
ibrain@ncable.net.au



Bulletin Editor

Steve Ezzy
AH: 5339 4821
Mob: 0400 160 158
blcceditor@hotmail.com



Positions Currently Vacant

Rally Panel Representative

JDP Co-ordinator

Sponsorship

Presidents Report July 2011

G'day and welcome to the July edition of BLCC's Bulletin

Saturday 2nd July Motorkhana Rnd 2 was under the guidance of Rod Hall. This event had thirty entrants and with some tricky motorkhanas chosen by Rod, soon saw everyone being sorted out to the point where there were a lot of double WD's for some tests. Thanks to the timers Rob Prosser, Kate Meyer and Mark Hunter.

After the lunch break a few less competitors took up the challenge of the day night Autocross. This finished fairly early and a small group of people went over to the clubrooms to wind down – just like the “days of old” before the drought changed everything. Also good to see some club members doing official duties for the recent George Derrick Memorial Rally organised by the CCRMIT in the Avoca area. Those I saw up there included Darren Wythe, Ange Rugg, Steve Wilson, Chris Petrie and Chris Hall. It was a very cold early start but after a big frost it turned out to be a very pleasant day in the bush.

Coming events – Barneys Double Banger was postponed due to lack of entries and our AGM of course will be on what is usually our club night. The 7th of August sees Ben McGee organising Motorkhana rnd 3 and 26th, 27th and 28th of August one of our major events takes place, the Winter Classic takes place under the guidance of Vince McDonald, Mark and Clare Bennett and a small team which includes Rod Hall, Barney Haddon and myself these

are two names that seem to pop up everywhere!. As is usually the case there will be no meeting in August due to the running of the Classic this will also provide a window of opportunity for you to put your name down to help out hope to see you there, put your name down.

The AGM – doors open at 6.00 pm and the meeting will be at 7.30 pm, the meal and then our guest speaker Mr Bob Watson at 8.00 pm. Tickets are \$38.00 per head for a three course meal, please phone Frank Devine to book and pay on the night or by direct deposit, Frank will take your money if you visit his car yard in Howitt St (5339 3999)

Barney's Double Banger – After lots and lots of discussion and Wednesday the 20th and again on Thursday 21st it was decided to postpone this event to a later date due to a number of factors.

1. Firstly, and most importantly, at the close of entries only 16 entries had been received. This had increased significantly by Thursday but this was still short of our break even point of 30 entries.
2. The track had been graded but it was extremely water logged.
3. A lot of key officials were not available on the day for various reasons.

This was not a n easy decision to make as those involved feel that they are damned if they do



and damned if they don't! If the event is postponed early then those that have entered and the officials etc, are let off early, but those still thinking about it are inconvenienced. If we hang out to the last minute for more entries, and then have to postpone the event then even more people are inconvenienced! It is a very hard decision to make.

Committee – 3 renominations for six positions on the committee – we will still be three short, so if you think you can contribute to the club, talk to the committee we could second 12 months.

Memberships = were due on the 30th of June – if you haven't paid talk to Wayne so as to remain a member of this great club.

If you have a cars on the club plate system then you must remain a financial member of the club to remain eligible to participate in this scheme, so NO Car Club Membership No Cheap Rego!

Our clubs one and only employee Rhonda Parkinson the cleaner of our clubrooms for the last few years has had to resign from this position due to ill health, she has been diagnosed with cancer – Committee and Members wish Rhonda a speedy recovery. See you all at the AGM for a great night.

Noel Peers
President

AUTO TEST

Khanacross Regulations

I. DEFINITION - KHANACROSS

1.1 Khanacross is defined by NCR 18A as:

a competition conducted on ~~predominantly~~ unsealed surfaces, **bitumen or a combination of both** and involving a series of timed tests of various layouts. Khanacross is not, and may not include, a speed event. No straight section of the course may exceed 100 metres in length without a turn of at least 90°. Each test shall be designed to test the acceleration, braking and general manoeuvrability of the vehicle and the skill and judgement of the driver. The course for each test shall be marked by the appropriate use of arrows and/or direction markers. Up to two competing cars may be permitted on each test at the same time, subject to prior approval by the CAMS CEO or his nominee. ~~No passengers may be carried in any vehicle during competition.~~

1.2 Course is defined as:

The description "course" shall apply to that individual path and combination of manoeuvres which a driver is required to complete in the prescribed manner.

2. THE COMPETITION

The object of the competition is for each driver to complete all the ~~tests courses~~ of the program in the prescribed manner, in the shortest possible time, without incurring penalties.

Khanacross events are regarded as one of the introductory levels in the spectrum of motor sport. They offer to clubs and Competitors the opportunity to conduct and take part in events conducted under the National Competition Rules of CAMS, in which the essential skills of car control and judgement may be practised under conditions which avoid the many hazards of public roads.

3. EVENT LAYOUT

3.1 Courses must not exceed 1.5km in length. ~~and may not include any sealed section greater than 50 metres.~~

No straight section of the course may exceed 100 metres in length without a turn of 90° or more, otherwise cars must stop in a garage. The 90° turn must pass through an established area of 10m x 10m (refer diagram 3.1.1). The Competitor should not normally be required to reverse while competing, at the Clerk of the Course's discretion. Markers shall clearly define the correct course to be taken.

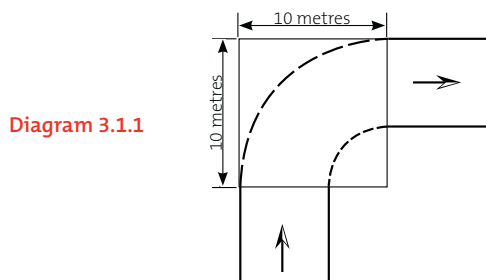

3.2 Courses should be designed to ensure that competing vehicles do not exceed 100km/h at any time during the tests and that the risk generated by vehicle speed is acceptable given the circumstances of the event.

Enclosures for paddock and/or spectator cars must be at least 10 metres from the course, unless protected by a barrier sufficient to stop a competing car, in which case they must be at least five metres from the course.

3.3 For each venue and layout and surface, consideration shall be given to the risk presented by the proximity to the course and the protection systems which are able to be employed, of enclosures for paddock and/or spectators and controls must be introduced to reduce the risk to an acceptable level.

3.4 The course shall be denoted by suitable markers or arrows. These should be made and placed so that they are easily seen by Competitors, especially if the event is to be run at night. All arrows should be placed approximately 1.2 metres above the ground.

3.5 Each ~~course test may shall~~ be used ~~more than only~~ once in each direction during an event.

3.6 Bunting, if used, should not be affixed to course markers.

3.7 Start/finish garages:

- (i) The Start/Finish garages may be the same garage or two separate garages. In either case the garages shall be



SPEED

Speed Event Standing Regulations

A Speed Event is subject to the general requirements of the National Competition Rules of CAMS save for such specific exceptions to the appendices thereof as are included in the following Standing Regulations:

1. DEFINITIONS – SPEED EVENTS

- 1.1 **Autocross:** A single-car speed event of less than 2km on a grass and/or unsealed surface, occasionally combined with sealed surfaces when conducted on a permanent circuit.
- 1.2 **Hillclimb:** A single-car speed event on a sealed or unsealed surface usually comprising a variety of gradients and corners.
- 1.3 **Lap Dash/Sprint:** A single car speed event on a sealed or unsealed surface, usually conducted on a permanent circuit, track or dragway.
- 1.4 **Supersprint:** A multiple-car speed event, similar to a lap dash, conducted on a permanent sealed circuit in which two vehicles start simultaneously. They may be followed, after a suitable gap, by two other vehicles starting simultaneously. Elapsed times and not relative positions at the finish line determine event placings.
- 1.5 **Other Events:** Other events may be determined to be speed events (see NCR 22) regardless of whether they are so described above; and may be described in other sections of the CAMS Manual of Motor Sport (eg, Rally/Road).

2. LICENCES

- 2.1 Drivers must hold a current membership card issued by one of the participating clubs together with at least a CAMS Level 2S or 2SJ licence.
- 2.2 Level 2S or 2SJ licences are applicable for events up to international level.
Refer to “General Regulations of CAMS” in the CAMS Manual of Motor Sport .
All licences must be presented at scrutineering.
- 2.3 **Drivers:** Two classes of drivers are provided for:
 - Junior, having attained the age of 14 years and not 16 years; and
 - Seniors, being those who have attained the age of 16 years.

3. TIMING

Each lap or run will be measured by electronic equipment and/or hand-operated watches, and recorded at a resolution of at least 0.1 second.

4. RE-RUNS

Re-runs are allowed at the sole discretion of the Clerk of Course. Usually, re-runs are approved only in the event of timing equipment failure (see Supplementary Regulations).

5. REPLACEMENT VEHICLE

A driver whose vehicle has broken down may use a replacement vehicle at the sole discretion of the Clerk of Course. The replacement vehicle must be scrutineered, should preferably be in the same class as the original vehicle, and must be used for the remainder of the competition.

6. PRACTICE

In Autocross events, practice of two laps shall be permitted to any driver unfamiliar with the course; practice for other competitors and in other events may be permitted by the Clerk of Course if deemed appropriate.

7. PROCEDURE

Competitors will be advised in Supplementary Regulations and/or at drivers’ briefing as to direction of travel, flag signals, mode of competition, the number of vehicles on the course simultaneously, the number of laps per “run”, starting order, starting procedure, procedure for returning to the pits and method of scoring.

8. METHOD OF SCORING

Placings will be decided on single or multiple lap times, as detailed in Supplementary Regulations; the winner being the driver with the shortest elapsed time for a single lap or multiple laps or a combination of either or both, again as detailed in Supplementary Regulations.

9. FLAGS

Flag signals and competitors’ responses thereto will be advised in Supplementary Regulations and/or at the drivers’ briefing.

Event Calendar



■ July

■ Friday 29th

BLCC Annual General Meeting

■ Saturday 30th

Rich River Revisited, HRA

■ Sunday 31st

Ready Plan Re-run

■ August

■ Saturday 6th

Baden Powell Introductory Trial Rover

Scout Motorsport

■ Sunday 7th

BLCC, Motorkhana 3

■ Saturday 13th

Cooper Memorial Rally Sprint

■ Sunday 21st

Geelong AX/KX R6- khanacross

■ Friday 26th

Winter Classic Rally and Tour

No Club Meeting

■ Saturday 27th

Winter Classic Rally and Tour

Ivans Folly

■ Sunday 28th

Winter Classic Rally and Tour

Victorian Hillclimb Championship

Round 7, Haunted Hills

■ September

■ Saturday 3rd

Mt Porpunkah Rally Spring

The Lions Rally

■ Saturday 10th

Mafeking Mahem

■ Sunday 11th

BLCC, Motorkhana 4 CDC6

Geelong Motorkhana R1

■ Saturday 17th

Marysville Stages, VCRS Round 4, CTS6

■ Sunday 18th

CSA Wheels Victorian Hillclimb

Championship Round 8 Rob Roy CDC7

Geelong AX/KX R7 - Autocross

■ Friday 30th

BLCC Club Meeting

■ October

■ Friday 7th

Bathurst 1000

■ Saturday 8th

Seemore stages round 2

■ Sunday 9th

Bathurst 1000

Proposed BBQ and Bathurst day at

BLCC Clubrooms. (register your interest

bathurst2011@blcc.net.au)

■ Saturday 15th

Akademos VRC4

■ Sunday 16th

Sandown Sprints CDC8

Geelong AX/KX R8 - khanacross

■ Friday 28th

BLCC Club Meeting

■ Saturday 29th

Bagshot Rallysprint

■ November

■ Saturday 5th

Coghlan's Carnival

■ Sunday 6th

Coghlan's Carnival

Geelong Motorkhana R2

■ Saturday 12th

Rally Victoria

■ Sunday 20th

Reserve Date for BLCC Autocross and Series

Geelong AX/KX R9 - Autocross

■ Friday 25th

BLCC Club Meeting

■ Saturday 26th

Alpine Rally

■ December

■ Saturday /Sunday 3rd /4th

Ararat One Tree Hillclimb

■ Sunday 11th

Geordie Fawcett Memorial Autocross,

Xmas Breakup

Geelong Come & try khanacross

CAMS Bronze Scrutiny Course

A CAMS Bronze Scrutiny training course will be held on Saturday 20th and Sunday 21st August 2011 in Shepparton, Victoria. The course provides a fantastic opportunity for CAMS members to broaden their understanding on motor sport officiating and allows officials to get up close and personal with cars at future events! The course will be highly interactive with both theory and practical based learning, all organised and presented by the helpful and friendly members of the Victorian Scrutiny Panel.

BRONZE SCRUTINY

Scrutineers are vital for any event as they are responsible for checking the compliance of vehicles and the eligibility and safety requirements of CAMS National Competition Rules.

The Competencies for this module are:

1. Perform the scrutineering functions expected of a motor sport Scrutineer
2. Identify risks and manage them accordingly
3. Manage difficult and critical situations through effective communication and interpersonal techniques.
4. Apply regulations and NCRs relevant to scrutineering at motor sport events.

The course will begin at 9am Saturday 20th August and will run for approximately 8 hours. The course is continued on Sunday 21st August, however the length of the day will depend on how much content is covered on Saturday. Places for the module are strictly limited so get in fast if you wish to attend! For more information on the course, such as exact location and course requirements or if you would like to enrol please contact Lewis White lewis.white@cams.com.au or Ben Manning ben.manning@cams.com.au on 1300 883 959.

Please pass this message onto all club members. For more information on other training courses, events and state news please follow the below link. <http://www.cams.com.au/States/Victoria.aspx>

Treasurers Report July 2011



- The Business Activity Statement financials for the April - June quarter has been submitted to the Accountant for reconciliation and annuals to be audited
- The old club account was closed 27/6/11 and remaining monies transferred to the new account
- The July 2 Autocross/Motokhana has been run but waiting on entry money.
- Quite a few direct credit payment of memberships have been occurring
- Health inspection has been completed. Hole in lino to be fixed and exhaust above stove required
- Annual lease of Autocross track of \$652.90 has been paid
- Receipts and payments for the month presented to committee
- BAS payment approx \$280.00 for the last quarter

Pay your membership from anywhere!!
Ballarat Light Car Club banking details
BSB No: 633-000
Account No: 141857458

Clare Bennett Treasurer 2010-2011 Mob: 0439 652 325 E: bennett@ncable.net.au

Your Club Get Involved

Editorial

Well that's it for another year. Unfortunately there have been no new applications for new members of the committee so the same crew, minus Ian Brain will be continuing on for the next year. Ian will continue to have input into the club but has limited time which means full time committee duties are not possible.

There have been some more tasks completed and jobs done around

the club not the least of which was Barney's servicing of the grader which is not a quick check of the oil and water I can assure you. Assisted by my own children I was finally able to install the second railing up the tower stairs, for anyone who welds for a living I apologise. The new stove and hot water service are now installed and functioning so the food will be hotter and there will actually be hot water in the toilets.

If you have been thinking about joining the committee there are still vacancies so if you missed the regular

application process then speak to one of our members and we will consider seconding you on.

There are also a number of jobs that can be done without being on the actual committee. The best on I think is the publishing of this particular publication others include, the various liaisons with various CAMS panels and other tasks within the club such as JDP and promotions. So, you don't even need to be on committee to be an active part of the club. We are also seeking a member willing to become a trainee treasurer, this is a skilled position and requires a period of introduction so think about having a go.

Club Permit Information

PROCESS FOR OBTAINING CLUB PERMITS FOR VEHICLES.

The following is the current process for getting your vehicle onto the Club Permit system.

First of all the vehicle must be a minimum of 25 years old (to the month) and in roadworthy condition. Current registration is not necessary. The owner **MUST** present a current Club membership card and **MUST** remain a member in order to continue to use the vehicle.

When ready contact the Clubs designated officer to arrange processing. (Details below.)

The vehicle is to be checked for suitability for use on Club Plates either with a roadworthy certificate or by myself as the designated officer. A nominal fee is charged for the check.

Once the paperwork is completed you go to Vic Roads for processing.

You have a choice of either 45 or 90 day permits, and it's a log book system which you are responsible for.

After you receive your plates and paperwork from Vic Roads (usually up to 3 weeks,) it is **YOUR** responsibility to notify me with the expiry date and plate details. The Club is responsible for keeping accurate records. At present that's me. Therefore, if you sell the vehicle, smash it, remove it from the road, don't renew your membership, or change Clubs, you **MUST** notify me and in some cases hand back the plates to Vic Roads.

RENEWING YOUR CLUB PERMIT.

When your permit is nearing its expiry date you will automatically receive a renewal from Vic Roads

which you then must get signed by me. At present the Club is asking a fee of \$5 for all renewals to help cover the cost of being a member of A.O.M.C. payable on me signing off your permit.

PLEASE REMEMBER THAT YOU ARE RESPONSIBLE TO MAINTAIN YOUR VEHICLE IN A ROADWORTHY STATE. SOME VEHICLES THAT HAVEN'T BEEN SEEN OUT AT THE CLUB FOR A WHILE MAY REQUIRE A CHECK TO BE CARRIED OUT PRIOR TO RENEWAL.

Chris Hall.

B.L.C.C. Club Permit officer.

53424397 or

0438094684. Leave details if need be. (Limited phone coverage at home.)

autoparts

PROFESSIONALS
BALLARAT



Lightforce Lights from \$359
Narva 225's from \$350



NEW 2011
Range of Bell
Helmets
from \$499



NEW for 2011 Indy 3
Boots \$199!



RPM Club Gloves \$89
Mechanics Gloves from \$29.95



Hydraulic Handbrake \$249



Don't forget Auto Parts Professionals gives discount to BLCC's Members!

Call in and see Nathan and David, for there huge range of stock, 7 days a week, for friendly advise and great prices, supporting the Ballarat light car club for 15 years!

Auto Parts Professionals, 9 Doveton St Nth, Ballarat, 53329333

News in Brief *continued*

on the petition, and returning it to us in the enclosed prepaid envelope before August 31 2011. Thank you for your assistance and support.

Club Historian

The committee is calling for expressions of interest from persons interested in becoming the club historian.

AGM guest speaker to promote LCCA book

Our guest speaker Bob Watson who will be speaking at the AGM is the author of a book which explores the history of the e Light Car Club of Australia (LCCA). Currently for sale at Autoparts this publication is will be explored and promoted at the AGM by Bob.

Direct Payments A Success

Several members and hopefully many more have taken advantage of the method of paying directly into the BLCC account. So give it a go, and pay for membership or event payments and make everything simpler for you and for the treasurer.

Winter Classic on FaceBook

Check out the FaceBook page for the Winter Classic Trial & Tour, be sure to click the like button.

<http://www.facebook.com/pages/Winter-Classic-Trial-and-Tour/191208827601526>

ROBSON GLASS

Established over 98 years

Shop Fronts



Broken Glass Replacement



24hr Emergency Service



Cut To Size Glass & Glazing



Insurance Work



Lead Lighting



Mirrors



Safety & Sound Proof Glass



Glass Splashbacks



Shower Screens



Double Glazing



W J ROBSON & SONS PTY LTD

5332 2078 MBL 0418 508 429

After Hours 5341 3898 or 5339 4664

Cnr Maun Rd & Humffray St Ballarat

Notice to Bulletin Advertisers

If you wish to place an advertisement, please consult the Treasurer, **Clair Bennett** (5330 2295 or 0439 652 325) who will arrange an invoice and pass the request to the Editor, **Steve Ezzy**, for inclusion in the appropriate issues.

Please see the table below for the Annual Fee for Advertising

Size	Annual Fee (\$)	1 Month Fee (\$)
Full Page	220	22
Half Page	143	14.30
Third Page	119	11.90
Quarter page	99	9.90
Sixth Page	89	8.90
Eighth page	79	7.90

Member Small adverts of the Buy, swap & Sell type will continue to be **Free**

Club Scrutineers

Chris Hall	Grade 2	5342 4397 0438 094 684
Noel Peers	Grade 3	5341 8124
Darren Wythe	Grade 3	0448 417 506
Ben McKee	Grade 3	5336 1172 0418 313 695
Wayne Webb	Grade 3	5334 7698

Liability Disclaimer – All material in this magazine represents the opinions of the authors and does not carry any endorsement by the Editor or the Committee, Ballarat Light Car Club has no official connection with any public or commercial organisation and it does not provide product recommendations. Names of commercial products mentioned in this magazine are registered names and trademarks of their owners. Copyright Notice – Material in this magazine may be copied by any other club without fee or written permission provided that the copyright rests with the Ballarat Light Car Club. The copies are not to be used for commercial advantage and the origins of the material and this permission to copy are acknowledged in the reprinted item. The Nissan Car Club-Australia is acknowledged as the source for the wording of this Disclaimer.

Sport Sub Committee Notes

Past Events

Winton – CDC round. Wet and foggy. Approx 7 BLCC competitors went. Richard Gay the quickest. Jim Hammond next in a trick XR8. Others that went were Chris Hall in Zed. Greg & Sharon Pitt in the CRX, Leon Pegg in the Commodore, J Leoncini in a Celica I presume and Benny McKee in whatever took his fancy (Escort Subaru ??)

Nissan Nightmoves run and won.

MK2 Rod Hall Clerk of Course. Timers Rob Prosser, Kate Meyer, Mark Hunter and Noel Peers. NP also chief scrutineer ably assisted by others. 30 Entries !! Ben McKee the quickest. Noel calculated the times.

AX Day Night. Damian Faulkner and Les Noonan were the Clerks of Course, Barney Haddon was the Steward. Noel Peers Chief Scrutineer again ably assisted. RH secretary and chief time keeper. Late start due to 30 entries above. Small field of 25. Roster worked OK but was busy. Rob Prosser manned the bottom of the bomber strip. Steve Ezzy provided food between events and Clare Bennett provided tea in AX tea break. Spaghetti Bolognese was great. Thanks Clare great initiative New stove works well apparently. 6 Competitive Runs were had. John Austin was quickest. Lights on tower lit up pit area exceptionally well. Grader became right to go during the competition. Thanks Barney and Mark Hunter Water truck wasn't needed as the big boss upstairs had his going beforehand. 2 Camiras now operational again and were used in the middle.

Steve Grinstead and Glenn Latter both went. to the VHC round at Morwell.

Coming Events

Barney's Double Banger. Roy Parko as steward. RH to ensure radios and timing gear is at the track in his absence.

MK3 on 7/8/2011 Ben McKee

MK4 Ash Findlay and Keith McElroy.

Winter Classis . Vince McDonald Clerk of Course. Needs lots of help. A coordinator of all the tests is needed.

3/09/2011 Seemore Stages 2 Wombat Forest. 30 crews. To be part of CTS unless someone misses out within previously published ruling. CTS Status is still OK.

Sunday 18th September Rob Roy Hillclimb VHC RD now also a BLCC CDC round. CDC7. WS to ensure Bulletin Calendar is updated. Was in Sports Sub notes but missed the Calendar.

General Business.

AX Track is now very worn and will need grading ASAP. Have a volunteer is willing if he can be shown how to do it..

Add Mark Hunter to list of Driving instructors list.

Subaru RX with front driveshafts removed to render it RWD will be allocated to specials class.

VCRS minutes were tabled but didn't seem to have any issues for us to be concerned with.

CAMS Bulletin re CAMS Standing Regs for Speed Events and Khanacross Events were distributed and read

Speed Event Already OK as it is pretty much what we have been doing.

Khanacross Standing Regs. Significant changes are made.

Allowed to use more bitumen (previously only 50m was allowed) but implied that permit will increase by 50%

Passengers are now allowed. YIPPEE!!

Minimum Age decreased from 14 to 12 years if instructor is present in the 12 & 13 year old's vehicle. Instructor to be approved by Clerk of Course or come from list published in Bulletin.

DNF's to be assigned Slowest Time +5Secs (as currently used) but DNS to be assigned slowest time +10 Secs.

The age change will allow Jr competitor to do 2 components of Cogs Carnival.

Need to add these Bulletins to Directors Kit and need to ensure directors download current standing regs from the CAMS website as they can and do change quarterly.





«AUGUST 26, 27 AND 28»

WINTER CLASSIC TRIAL & TOUR

more information and expressions of interest to: bennett@ncable.net.au



2011 AUG INFORMATION

PRESENTED BY BALLARAT LIGHT CAR CLUB



NOW IN ITS 14TH YEAR
BITUMEN ONLY EVENT!

The Ballarat Light Car Club's Winter Classic Rally & Tour returns for 2011. The weekend starts with a BBQ dinner on Friday night and a run under lights to kick the event off at the Showgrounds. Saturday you have your choice of, Tour or the TRE and then the first of our driving tests Saturday evening has us sharing tales of a different style, Sunday brings challenges of a different style, concluding at our historic clubrooms.

[HTTP://WINTERCLASSIC.BLCC.NET.AU/](http://winterclassic.blcc.net.au/)

E-mail Notifications.

A new e-mail notification system has been implemented on our site to simplify the process of keeping members and other interested parties informed of goings on in the club.

Sign up to receive event updates and announcements from Ballarat Light Car Club about upcoming events and activities. E-mail announcements will be sent out occasionally about website-related activities and new website features.

Note: this feature is not in place of the electronic send out of the club newsletter. And all recipients of the bulletin should feel free to sign up for notifications.



Proposed Members Business Register

I was pondering how I was going to find someone to complete the removal of a huge amount of Wisteria from my side fence. I considered the phone book for a moment and as I did so I thought about who in the BLCC might know someone from the club who knew someone? I was then prompted to think about the amount of useful information that could be collated into a list of useful business / skills / hobbies that people have, do or run.

To this end I thought I might put my idea out there, I will collect a list of members (proposed to me) of people who are likely to be useful to other members. I do not propose that there be any discounts or freebies just a list of people and their field of expertise.

So, if you make stickers, weld up roll cages, are an expert in suspension, electronics, gardening, office supplies, sell bolts, make trailers, are a retired business man willing to offer advice, are an expert in IT or lay cement than you should be on this list.

If you would like to be on this list (Name, Number and field) then SMS or Phone me Steve Ezzy 0400 160 158 or email blcceditor@hotmail.com

Members listed below have nominated themselves as being willing to assist fellow members

Peter Ellis (Driving Ambition) Driver Training Specialist to Individuals and Business - Mobile 0419 002 007 Tel. (03) 5334 3144



Mechanica Industries

design·create·repair·salvage

- Mechanical engineering
- Automotive maintenance & repairs
- Machine shop
- On-site maintenance

*If its metal, we can design it, create it, repair it or salvage it.
At Mechanica Industries, we love machines!*

Mechanica Industries are located at **12 Paddys Drive Delacombe 3356**

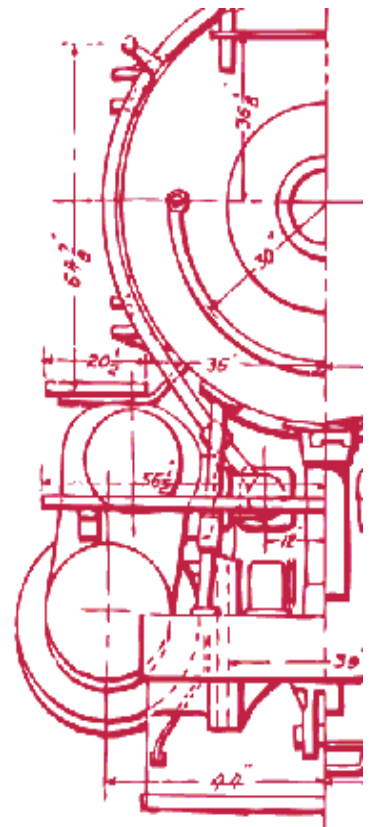

www.mechanicaindustries.com.au

5335 7251

DAY NIGHT AUTOCROSS

BALLARAT LIGHT CAR CLUB

No	Name	Car	Class	Prac Time	Prac Hats	Run1 Time	Run1 Hats	Run2 Time	Run2 Hats	Run3 Time	Run3 Hats	Run4 Time	Run4 Hats	Run5 Time	Run5 Hats	Run6 Time	Run6 Hats	Best 5/6	OR Posn	Class Posn	
OUTRIGHT																					
67	John Austin	Lancer Evo	F	86.451	1	80.576		79.195		78.82		77.533		66.361		64.425		371.334	1	1	
68	Ben McKee	Subaru	F	84.844		83.254		82.889		82.205		80.839		66.976		66.137		384.046	2	2	
69	Damian Faulkner	Subaru	F	84.326		83.867		83.928	1	82.912		82.466		69.532		67.602		391.379	3	3	
65	Peter Seid	Subaru RS Turbo	F	86.74		89.496		85.987		86.366	2	84.411		69.935		68.674		403.503	4	4	
69	Chris Hall	Datsun 260Z	I	88.08		87.581		86.674		85.133		84.794		71.094		71.409		404.104	5	1	
66	Mick Goossens	Subaru RS Turbo	F	86.858		87.083		89.46		86.116		85.434		69.831		70.909		404.373	6	5	
54	David Marmo	Corolla	A	88.173	1	88.633		86.425		86.898		85.767		72.085		70.931		407.106	7	1	
60	Ben Davis	Corolla	C	89.114		89.086		87.934		87.642		86.025		70.831		70.246		407.678	8	1	
62	Daniel Keirce	Datsun 1601	C	86.942		87.29		93.87		85.82		84.296		73.804	1	70.163		411.373	9	2	
61	Darren Wythe	Datsun 1600	C	89.849		89.011	1	88.693		87.243		86.674		71.745		72.033		411.388	10	3	
50	Stefan Dekker	MR2	A	89.543		89.118		89.309		87.117		86.88		73.62		70.668		412.403	11	2	
70	Daniel Hall	Pulsar	I	87.36		88.464		85.714		85.653		84.661		73.595	1	73.475		413.098	12	2	
64	Les Noonan	Mazda Familia	F	91.589		89.197		87.96		88.062		86.239		74.946		74.33		414.537	13	6	
56	Paul Gladman	Pulsar	A	92.57		91.838		89.292		89.315		87.087		74.174		74.076		418.944	14	3	
53	Robert Dekker	Laser	A	91.166		88.892		88.96		89.943		87.028		75.371		74.398		419.649	15	4	
51	David Jowett	Pulsar	A	92.954	1	91.362		90.151		93.782	1	88.619		73.122		72.901		421.155	16	5	
71	Craig Hunter	Bluebird	J3	94.678	1	93.312		91.184		94.206		89.041		74.051		73.996		426.584	17	1	
57	Evan Dekker	MR2	A	90.782		106.661	WD	87.577		92.332		86.621		81.337		75.153		428.020	18	6	
58	Jim Hammond	Falcon	B	93.996	1	94.498		91.293		99.241	1	90.805		76.956		74.401		432.953	19	1	
52	Matthew Davies	Corolla	A	110.987		101.661		98.904		95.336		92.943		81.398		78.603		452.184	20	7	
73	Kate Meyer	Stanza	L	99.865		98.201		96.926		94.346		102.945		77.333		80.963		452.769	21	1	
74	Stacey Noonan	Mazda Familia	L	95.292		93.424	1	91.46		90.267	1	90.059		91.775	1	77.94		456.501	22	2	
55	James Scott	BMW 318i	A	102.363		100.644		97.898		108.931	1	98.125		83.83		81.554		467.051	23	8	
72	Brayden Hammond	Falcon	J3	100.923		101.353		103.904	WD	98.496		97.875		84.77		80.194		467.688	24	2	
59	Henk Dekker	Sprinter	C	95.225		96.108		95.769		94.373	1	93.602	1	82.867		90.192		468.538	25	4	
CLASSES																					
Up to 1800cc Std																					
54	David Marmo	Corolla	A	88.173	1	88.633		86.425		86.898		85.767		72.085		70.931		407.106	7	1	
50	Stefan Dekker	MR2	A	89.543		89.118		89.309		87.117		86.88		73.62		70.668		412.403	11	2	
56	Paul Gladman	Pulsar	A	92.57		91.838		89.292		89.315		87.087		74.174		74.076		418.944	14	3	
53	Robert Dekker	Laser	A	91.166		88.892		88.96		89.943		87.028		75.371		74.398		419.649	15	4	
51	David Jowett	Pulsar	A	92.954	1	91.362		90.151		93.782	1	88.619		73.122		72.901		421.155	16	5	
57	Evan Dekker	MR2	A	90.782		106.66	WD	87.577		92.332		86.621		81.337		75.153		428.020	18	6	
52	Matthew Davies	Corolla	A	110.987		101.661		98.904		95.336		92.943		81.398		78.603		452.184	20	7	
55	James Scott	BMW 318i	A	102.363		100.644		97.898		108.931	1	98.125		83.83		81.554		467.051	23	8	
Over 1800cc Std																					
58	Jim Hammond	Falcon	B	93.996	1	94.498		91.293		99.241	1	90.805		76.956		74.401		432.953	19	1	
Up to 1800cc Mod																					
60	Ben Davis	Corolla	C	89.114		89.086		87.934		87.642		86.025		70.831		70.246		407.678	8	1	
62	Daniel Keirce	Datsun 1601	C	86.942		87.29		93.87		85.82		84.296		73.804	1	70.163		411.373	9	2	
61	Darren Wythe	Datsun 1600	C	89.849		89.011	1	88.693		87.243		86.674		71.745		72.033		411.388	10	3	
59	Henk Dekker	Sprinter	C	95.225		96.108		95.769		94.373	1	93.602	1	82.867		90.192		468.538	25	4	
Four Wheel Drive																					
67	John Austin	Lancer Evo	F	86.451	1	80.576		79.195		78.82		77.533		66.361		64.425		371.334	1	1	
63	Ben McKee	Subaru	F	84.844		83.254		82.889		82.205		80.839		66.976		66.137		384.046	2	2	
68	Damian Faulkner	Subaru	F	84.326		83.867		83.928	1	82.912		82.466		69.532		67.602		391.379	3	3	
65	Peter Seid	Subaru RS Turbo	F	86.74		89.496		85.987		86.366	2	84.411		69.935		68.674		403.503	4	4	
66	Mick Goossens	Subaru RS Turbo	F	86.858		87.083		89.46		86.116		85.434		69.831		70.909		404.373	6	5	
64	Les Noonan	Mazda Familia	F	91.589		89.197		87.96		88.062		86.239		74.946		72.33		414.537	13	6	
Specials																					
69	Chris Hall	Datsun 260Z	I	88.08		87.581		86.674		85.133		84.794		71.094		71.409		404.104	5	1	
70	Daniel Hall	Pulsar	I	87.36		88.464		85.714		85.653		84.661		73.595	1	73.475		413.098	12	2	
Juniors 16&17 Yrs																					
71	Craig Hunter	Bluebird	J3	94.678	1	93.312		91.184		94.206		89.041		74.051		73.996		426.584	17	1	
72	Brayden Hammond	Falcon	J3	100.923		101.353		103.9	WD	98.496		97.875		84.77		80.194		467.688	24	2	
Ladies																					
73	Kate Meyer	Stanza	L	99.865		98.201		96.926		94.346		102.945		77.333		80.963		452.769	21	1	
74	Stacey Noonan	Mazda Familia	L	95.292		93.424	1	91.46		90.267	1	90.059		91.775	1	77.94		456.501	22	2	



Autocross Motokhana and Khanacross facilities at risk

Over the past few years the committee of the Ballarat Light Car Club has been monitoring Ballarat City Council discussions and community rumours surrounding the future uses of the crown lands commonly known as the Ballarat Airport Precinct.

Of particular concern has been that the draft plans appear to presume a takeover of our CAMS accredited and nationally recognised Autocross (AX) Khanacross (KX) and Motokhana (MK) facilities, together with the buildings and water storage that we and past members have spent many years, many working bees and many dollars constructing.

As you probably know, these facilities are central to the life of our club. While we conduct forest rallies and Touring Road events on behalf of our members and the wider Motorsport community, the club's AX, KX and MK facilities underpin these activities, and in fact provide probably the best and only facility for controlled-environment Motorsport driver development and driver and officials' skill training in the region. As you certainly know, in Motorsport circles Ballarat Light Car Club is renowned and respected for the standard and preparation of its events - something that has been the case for the entire 60 years of its existence - and something the current committee hopes to continue.

Yet it seems this very existence may be under threat. Progress, and the expansion and growth of Ballarat means that our Airport Precinct is being eyed as an "Employment Zone", meaning development and factories and warehouses, but not motorsports facilities. Without these facilities it is not at all likely that BLCC would survive.

Ballarat Light Car Club has passed the following resolution and is hoping to have it supported by our local council. In order to have it considered, we need to present it as a petition. The resolution and its preamble is this:

The Ballarat Light Car Club understands that proposed future alternative development and possible uses of the Crown Lands and facilities previously and presently given over to its care, and leased to it from the State of Victoria through the offices of the City and formerly Shire of Ballarat, may mean these facilities will cease to be available to the club for its current and future purposes.

Bearing in mind that the use, management and benefit of these facilities has been a part of the life of the Ballarat community for the past 60 years, and that they remain a wanted and needed resource for the future; and further bearing in mind that the total and complete development and maintenance of these facilities has been undertaken by the voluntary effort and donation of members of the Ballarat Light Car Club, the Ballarat Light Car Club requests formal consideration and endorsement of the following resolution by Council of the City of Ballarat:

Should Council of the City of Ballarat determine that - in the greater interest of the Ballarat Community - the lands facilities and resources currently occupied, managed and used by the Ballarat Light Car Club are to be required for other purposes, that Council will ensure that the facilities be replaced, relocated, and/or substituted on a 'Like with Like or Better' basis.

We ask you, as a Motorsport supporter, to assist us by obtaining signatures of support on the attached petition, and returning them to us in the enclosed pre-paid envelope **before August 31 2011**. Thank you for your assistance and support.

NOEL PEERS
President

WEBB ALLTRADES **WEBB SIGNS**

House & Home

- House Renovations & repairs
- Plasterboard Hanging & Finishing
- Floor & Wall Tiling
- Concreting, Shed slabs, path's, driveways
- Tree felling & lopping
- Any size job
- Quality work
- Upholstery coming soon!

Signs & Graphics

- Race & Rally Signage
- Magnetic Signs
- Boards, Banners & A Frames
- Shop front & Business signage

Vehicles

- Competition car preparation, Panel beating & Spray painting
- Welded Rollcages to Cams specs
- General welding(Cert. 8G) & fabrication.

Wayne & Angela Webb
10 Frawleys Rd, Leigh Creek, 3352
PH:53 347698 OR MOB:0438 347 698
Email: webballtrades@westnet.com.au

Sport Sub Committee

Rod Hall (Chair) Barney Haddon, Ben McKee, Darren Wythe (Rally Liason), Damian Faulkner, Steven Richards, Wayne Sleep, David Marmo, Peter Marmo, Ben Davis.

Meetings: Wednesday night immediately prior to monthly committee meeting.

Leaving the complex after Scrutineering

If a competition vehicle needs to leave the motor sport complex, you must remove your numbers so the Police or Vic Roads don't nab you. Also the vehicle needs to be re-presented for scrutiny upon its return before continuing competition.

For Sale

Slightly used 15 inch rally tyres and some alloy rims to suit a Datsun
 Please contact Chris Hall on 53424397 or 0438094684.

CTC Series Competitors: Early Entry

This year, the general lack of rallies is causing events to fill up fast. To make sure you get a run, you will need to enter quickly when entries open.

The Sport Sub Committee has decided not to remove events from the CTC Series if someone misses out, unless they have entered within 10 days of entries opening for that event and been refused

<i>Club Driving Instructors</i>					
John	Bourke	Wayne	Drew	Rod	Prosser
Richard	Gay	Gary	Harrowfield	Barney	Haddon
Mick	Goossens	Engles	Leoncini	Peter	Ellis
Les	Listen	Simon	Ellis	Darren	Wythe
Darren	Everett	Ben	McKee	Steve	Richards
Damian	Faulkner	Russell	McKenzie	Mark	Fawcett
Ben	Fawcett	Steve	Wilson	Chris	Hall
Keith	McElroy	Ben	Davis	Mark	Hunter

OUTRIGHT	Competitor	Vehicle	Class	Test 1		Test 2		Test 3		Test 4		Test 5		Test 6		Total Time	OR Result	Class Result
				Square Slalom		Gables		Open Slalom		Double Bone		Tri- Angles		Waltz Slalom				
				Time	Pens	Time	Pens	Time	Pens	Time	Pens	Time	Pens	Time	Pens			
	Ben McKee	Subaru	F	27.03		44.66		30.22		38.38		37.06		37.69		215.04	1	1
	Leon Pegg	Gemini	H	30.63		48.15		31.60		41.60		39.03		41.65		232.66	2	1
	Greg Pitt	Honda	C	31.37		50.66		31.89		42.63		38.41		45.50		240.46	3	1
	Robert Schenk	Laser	B	32.53		48.44		33.50		43.90		39.65		46.85		244.87	4	1
	Chris Hall	Datsun 260Z	I	31.19		50.91		32.84		43.50		42.28		44.41		245.13	5	1
	Ben Davis	Corolla	C	31.28		51.43		33.91		41.75		41.15		45.88		245.40	6	2
	Daniel Hall	Pulsar ET	I	34.94		56.09		33.22		42.13		38.06		47.25		251.69	7	2
	Darren Wythe	Datsun 1600	C	31.82		51.93		33.53		43.25		42.10		49.22		251.85	8	3
	Ian Walsh	Laser	C	32.19		54.12		35.13		44.72		42.13		46.75		255.04	9	4
	Paul Gladman	Pulsar	A	33.91		52.60		34.25		43.88		43.87		49.53		258.04	10	1
	David Marmo	Corolla	A	34.18		53.40		36.25		43.22		39.78		55.00		261.83	11	2
	Stefan Dekker	MR2	A	33.50		52.75		39.59	H	43.97		44.94		50.78		265.53	12	3
	David Jowett	Pulsar	A	36.50		53.00		34.75		45.28		61.53	WD	43.75		274.81	13	4
	Craig Hunter	Bluebird	J2	35.94		60.50		45.34	HH	47.27		46.85	H	47.81		283.71	14	1
	Henk Dekker	Sprinter	C	38.22		55.97		38.22		47.60		61.53		50.78		292.32	15	5
	Evan Dekker	MR2	A	33.56		54.88		39.19		53.16		53.93	HH	58.34		293.06	16	5
	Sharon Pitt	Honda CRX	L	31.09		51.10		32.72		42.81		61.53	WD	75.38	WD	294.63	17	1
	Matt Davies	Corolla	A	38.12		58.59		35.47		51.15		61.53	WD	50.03		294.89	18	6
	Jim Hammond	Falcon	B	38.75		64.12		51.85		40.10		50.25		51.69		296.76	19	2
	Robert Dekker	Laser	A	34.60		54.19		36.40		76.76	WD	48.75		50.81		301.51	20	7
	Brayden Hammond	Falcon	J2	40.53		64.22		41.16		53.97		45.94		58.41		304.23	21	2
	Marc Salter	Laser	A	33.10		55.25		36.16		44.62		61.53	WD	75.38	WD	306.04	22	8
	Peter Jowett	Pulsar	J1	40.09		66.09		41.66		54.19		44.96		61.50		308.49	23	1
	Bronwyn Salter	Corolla	L	39.12		67.59		60.44	WD	67.75		48.84		57.06		340.80	24	2
	Peter Seid	Subaru	F	35.53		58.03		34.35		76.76	WD	61.53	WD	75.38	WD	341.58	25	2
	Rhys Lane	Honda Civic	J1	42.10		63.69		42.19		52.72		55.59		87.03		343.32	26	2
	Andrew Bayley	Peugeot	J3	43.97		70.53		45.38		57.06		56.53		71.44		344.91	27	1
	Chantelle Hammond	Camira	J1	47.15		72.44		46.53		58.00		53.40	H	75.38	WD	352.90	28	3
	Heath Salter	Laser	J1	45.28		72.06		46.65		60.18		61.53	WD	75.38	WD	361.08	29	4
	Jessica Meyer	Camira	J1	55.97		91.06		69.81		66.12		61.53	WD	75.38	WD	419.87	30	5
	Fastest Time			27.03		44.66		30.22		38.38		37.06		37.69		215.04		
	Slowest Time			55.97		91.06		76.88		77.03		56.53		131.63				
	Slowest + 5 Secs			60.97		96.06		81.88		82.03		61.53		136.63				
	Double Fastest			54.06		89.32		60.44		76.76		74.12		75.38				

BOLD TIMES ARE FASTEST TIME FOR THAT TEST

CLASSES	Vehicle	Class	Test 1		Test 2		Test 3		Test 4		Test 5		Test 6		Total Time	OR Result	Class Result
			Square Slalom	Gables	Open Slalom	Double Bone	Tri- Angles	Waltz Slalom	Time	Pens	Time	Pens	Time	Pens			
UP TO 1800 STD																	
		A															
Paul Gladman	Pulsar	A	33.91	52.60	34.25	43.88	43.87	49.53	258.04	10	1						
David Mairmo	Corolla	A	34.18	53.40	36.25	43.22	39.78	55.00	261.83	11	2						
Stefan Dekker	MIR2	A	33.50	52.75	39.59	43.97	44.94	50.78	265.53	12	3						
David Jowett	Pulsar	A	36.50	53.00	34.75	45.28	61.53	WD	274.81	13	4						
Evan Dekker	MIR2	A	33.56	54.88	39.19	53.16	53.93	HH	293.06	16	5						
Matt Davies	Corolla	A	38.12	58.59	35.47	51.15	61.53	WD	294.89	18	6						
Robert Dekker	Laser	A	34.60	54.19	36.40	76.76	WD	50.81	301.51	20	7						
Marc Salter	Laser	A	33.10	55.25	36.16	44.62	61.53	WD	306.04	22	8						
OVER 1800 STD																	
		B															
Robert Schenk	Laser	B	32.53	48.44	33.50	43.90	39.65	46.85	244.87	4	1						
Jim Hammond	Falcon	B	38.75	64.12	51.85	40.10	50.25	51.69	296.76	19	2						
UP TO 1800 MOD																	
		C															
Greg Pitt	Honda	C	31.37	50.66	31.89	42.63	38.41	45.50	240.46	3	1						
Ben Davis	Corolla	C	31.28	51.43	33.91	41.75	41.15	45.88	245.40	6	2						
Darren Wythe	Datsun 1600	C	31.82	51.93	33.53	43.25	42.10	49.22	251.85	8	3						
Ian Walsh	Laser	C	32.19	54.12	35.13	44.72	42.13	46.75	255.04	9	4						
Henk Dekker	Sprinter	C	38.22	55.97	38.22	47.60	61.53	50.78	292.32	15	5						
4WD																	
		F															
Ben McKee	Subaru	F	27.03	44.66	30.22	38.38	37.06	37.69	215.04	1	1						
Peter Seid	Subaru	F	35.53	58.03	34.35	76.76	WD	75.38	341.58	25	2						
Historic																	
		H															
Leon Pegg	Gemini	H	30.63	48.15	31.60	41.60	39.03	41.65	232.66	2	1						
Specials																	
		I															
Chris Hall	Datsun 260Z	I	31.19	50.91	32.84	43.50	42.28	44.41	245.13	5	1						
Daniel Hall	Pulsar ET	I	34.94	56.09	33.22	42.13	38.06	47.25	251.69	7	2						
Juniors 12&13yrs																	
		J1															
Peter Jowett	Pulsar	J1	40.09	66.09	41.66	54.19	44.96	61.50	308.49	23	1						
Rhys Lane	Honda Civic	J1	42.10	63.69	42.19	52.72	55.59	87.03	343.32	26	2						
Chantelle Hammond	Camira	J1	47.15	72.44	46.53	58.00	53.40	H	352.90	28	3						
Heath Salter	Laser	J1	45.28	72.06	46.65	60.18	61.53	WD	361.08	29	4						
Jessica Meyer	Camira	J1	55.97	91.06	69.81	66.12	61.53	WD	419.87	30	5						
Juniors 14&15yrs																	
		J2															
Craig Hunter	Bluebird	J2	35.94	60.50	45.34	47.27	46.85	H	283.71	14	1						
Brayden Hammond	Falcon	J2	40.53	64.22	41.16	53.97	45.94	58.41	304.23	21	2						
Juniors 16&17yrs																	
		J3															
Andrew Bayley	Peugeot	J3	43.97	70.53	45.38	57.06	56.53	71.44	344.91	27	1						
Ladies																	
		L															
Sharon Pitt	Honda CRX	L	31.09	51.10	32.72	42.81	61.53	WD	294.63	17	1						
Bronwyn Salter	Corolla	L	39.12	67.59	60.44	67.75	48.84	57.06	340.80	24	2						

BOLD TIMES ARE FASTEST TIME FOR THAT TEST



P.O. Box 400
Ballarat
Victoria
3353

Fellow Clubmembers.

As you will be aware Ballarat Light Car Club has resolved to seek “Like with Like” restitution to enable us to relocate the club’s motorsports and driver training facilities when it is compulsorily acquired for the Airport warehouse zone re-development.

In order to have our request formally considered by Ballarat City Councillors, we are required to present them with a petition.

The minimum number of signatures required for a petition is 20.

Your committee has prepared an appropriate petition, but believes this is also an opportunity to demonstrate to Council the depth of support this club and our activities and our driver training has in the Ballarat Community, so we are seeking your direct assistance in gathering signatures of support.

Our target is 1000 signatures.

The committee has prepared a petition kit with pre-paid return envelopes for a two month campaign to gather and collate the petition.

The club is asking you to spread this petition throughout the Ballarat Community.

Milk Bars. Fish and chip shops, offices, retail stores, pubs clubs, shops, the motor vehicle industry, via your friends, through your kids at school, anywhere where people can come into contact with the petition.

So please, can you do your part to get some signatures on the petition, and take responsibility for returning them back to the club for collation and presentation before the end of September.

If you need additional copies, please contact a committee member who will arrange to get them to you.

The final date for return is two months after the AGM, i.e. the September Clubnight on Friday 30th September, where we’ll add up what we’ve got.

Thanks for your Assistance, let’s show Council the level of support that’s out there in the Ballarat community for motorsport.

Committee of the Ballarat Light Car Club.

History Slice



Andrew Dellaca and his 1964 Mini are a force to be reckoned with.

Mini man has the force with him

It is a pocket rocket and with Andrew Dellaca at the wheel, the pairing have become a force to be reckoned with.

As frontrunner in the Ballarat Light Car Club drivers' championship, Delaca has pushed his 164 Mini to the edge and looks set to continue his winning form and hopefully snaring the drivers' title.

Dellaca's interest in motorsport and Minis can be easily traced to his father John, who was a top competitor throughout the Mini heydays of competition in the '70s.

The latest Dellaca powerhouse began as an abandoned derelict that Andrew picked up at auction for \$25.

"it was my first car and then we slowly built into a club car using some of the bits dad had left over from his racing" Dellaca said.

His strong performances in the car club drivers, championship have already included clinching the autocross series, backed by some top ranking drives at hill climbs and circuit events.

The move to the track is one that appeals to Dellaca, especially when it comes to providing a measure on improvement.

"the Mini is great, but I would like to get into something like Formula Fords and do some proper track racing" he said.

Motor torque with Stuart McLagan

Membership

WELCOME NEW MEMBERS



Ross Barnett is the one new member this month. Ross was introduced by Andrew Harden and Chris Bourke, welcome to the Club.

Over the past few weeks I have spent quite a lot of time entering and updating membership details on the Database, printing and posting cards etc., I have learnt some new computer skills, thanks to Steve Ezzy for guiding me through. I think I have accounted for everybody that has renewed but I am still in the mail out process, so if you need your card urgently contact me and I will get it to you. We currently have 100 members.

A reminder to expired members with Club Plates. You must maintain a current membership for your plates to be legal and avoid a messy situation involving yourself and the club.

I recently spent a couple of weeks in W.A. Visiting my son Mike and new grandson. We borrowed his Nissan 200sx Silvia to go on a "Sports car tour" of the South West and Margaret River region, very pleasant place and nice driving (it would have been better without a nervous passenger), took pictures of the car in various places as you do on these trips. Road Test on the car, great, power, handling etc but it is no long distance Grand Tourer, with a cannon exhaust, minimal sound deadening and quite tight suspension these two tourists were a little jaded by the end of the 1500k trip. Good fun but.

Anyway see you at the Club,
Regards Wayne.

A reminder for all email recipients of this publication, please keep your email address current with the membership secretary.

Wayne Sanders
Email: w.sanders@optusnet.com.au

Phone:
AH: 5334 2330
Mob: 0412 713023



2011 Hillclimb Calendar

Calendar for 2011

Round 7 – VMCI Haunted Hills
F8 28th August

Round 8 – MGCC 18th September



History of the Light Car Club of Australia

*Authored by our AGM guest speaker in 2011
Bob Watson*



Available on the night or from Autoparts Professionals

Getting Social

Stay informed join us on Facebook and Twitter



Ballarat Light Car Club



BallaratLightCC

CAMS Welcomes New SCDO

June 09, 2011

CAMS welcomes Benjamin Manning to the role of Victorian Sport & Club Development Officer (SCDO).

Ben brings to the role a keen interest in motor sport especially development at grassroots level, having just completed a Double Degree in Sport Science and Sport Management.

Having commenced with CAMS on the 18th of May Ben has since spent his time bringing himself up to speed on the many facets of CAMS and the Motor Sport Community, while organising club forums and regional trips to meet with clubs unable to attend State Councils.

The SCDO role is an integral part of CAMS' commitment to servicing its clubs and members and Ben is looking forward to working with all Victorian members to help grow and develop motor sport in Victoria.

To contact Ben please call the CAMS hotline on 1300 883 959 or via email Ben.Manning@cams.com.au

CAMS New SCDO at VHC Ararat

June 17, 2011

Hello CAMS members, my name is Ben Manning and I am your new Victorian Sport and Club Development Officer. I have recently completed a Sports Management degree at Deakin University and I have 4 years of experience working with a grass roots sporting club. I am very excited about my new role and I am looking forward to working alongside Lewis White, and together with all of our CAMS affiliated car clubs, to grow our sport in every way possible.

I have already had the pleasure of attending my first event. On Sunday June 5th my regional manager and I headed down the Western Highway to Ararat for the 5th round of the State Hillclimb Championships. My first impression of the scenic, tree-saturated atmosphere was one of confusion. I am still unsure as to how such a setting could be titled 'One' Tree Hill. None the less, as we made our way from the car park to the spectator area, my confusion was soon overtaken by excitement as the first few cars began to tear their way up the Hill. I enjoyed chatting with competitors who showed genuine enthusiasm for the fantastic location, speed and layout of the track. I would like to thank Cheryl Healey from the Ararat Car Club for taking me up the Hill during a break. I thoroughly enjoyed watching the field of over 70 competitors negotiate their way through the chicane from my very own personal vantage point. For the record, the highlight of the day was Kevin MacKrell's final run in his Datsun 260z, where he recorded the fastest time for the day of 37.72 seconds. I had a great time at Ararat and am very much looking forward to my next opportunity to attend an event.

In the mean time please feel free to contact me at the office with anything club related. I am really keen to get involved and I look forward to meeting all of you in the future

Source : CAMS Speed Read

CAMS Upcoming Training

Sat/Sun 20th/21st August	Bronze Scrutiny Course	Shepparton Car Club
Wednesday 24th August	Bronze Fire & Rescue Training Course	CAMS
Monday 12th September	Bronze Stewards Course	CAMS
Thursday 27th October	Club Chief Training Course	CAMS
Monday 14th November	Event Assessor Training Course	CAMS

2011 AGM Guest Speaker (insight)

Bob Watson



Bob Watson is an inaugural inductee in to the Victorian Rally Hall of Fame. He is the recipient of a Confederation of Australian Motor Sport Service Award, and is a life member of the Historic Rally Association. He has been a member of the committees of the Austin Seven Club of Victoria, The GMH Motoring Club, the Light Car Club of Australia, the Historic Rally Association and has served on numerous CAMS committees and sub committees.

Born 27 December 1938. Married to Heather, with one son, Daniel.

1959 Obtained a Diploma of Mechanical Engineering at Caulfield Technical College, Melbourne

1959 Started work as an engineering cadet at General Motors Holdens

1960-1963 Worked in Holdens Experimental Engineering department as a technical report writer, then as an engine development engineer.

1964 Given a special project to review and develop solutions to Holden oil leak warranty problems. Developed new techniques for quality checking and performance testing of oil seals for all Holden

applications.

1966 Chassis development engineer in Holdens Experimental department

1967 Spent 12 months at Vauxhall Motors Luton UK as an engine development engineer.

1968 Returned to Holden and became chassis development engineer working on the development of the Holden GTS 327 Monaro as a vehicle to win the 1968 Hardie Ferodo 500 mile touring car race at Bathurst. Holden finished 1st, 2nd and 3rd in the race.

1969 Appointed brake design engineer, with a special project to develop an oil cooled brake system for the GTS 350 Monaro for the 1969 Hardie Ferodo Bathurst 500 mile race. Lack of development time and the change from the Monaro to the Torana GTR XU1 as Holdens competition vehicle prevented the project being completed. The oil cooled brake system was later installed to the Holden Hurricane concept vehicle.

1969 Became mainstream Holden brake design engineer. Designed HQ model braking system, including the introduction of ventilated front rotors, sliding calliper and rear brake proportioning valve.

1970 Left Holdens to take up the position of Motor Sport Competition Manager



for Renault Australia, running its state and national rally programs and driving Renault cars in major rally events.

1973 Accepted position with Bendix Automotive (a major supplier of components to Holden and Ford) as the Bendix Resident Engineer at Holden. Worked with Holden

engineers on the development of carburetors and fuel system components to meet the 1976 emission control regulations, and on power steering applications.

1976 Son Daniel born in July

1977 Accepted an offer from Renault Australia to organize the running of a team of four Peugeot 504 Australian entered cars in the 1977 Singapore Airlines London to Sydney marathon car rally. Granted time off from current job by Bendix for this project. See Motorsport history.



1977 Returned to Holdens to resume Bendix Resident Engineer position. However position had been made redundant by Holden's decision to use its own Rochester division to supply carburetors. Was offered position as Assistant Chief Engineer at Bendix Mintex, brake component suppliers located in Ballarat Victoria, but decided to start own business.

1978 Established Bob Watsons Service Centre in Hawthorn, Victoria in partnership with Bruce Shepherd, a former mechanic with the Renault Rally team.

1990 Sold out interest in Bob Watson's Service Centre to Bruce Shepherd.

1990-1992 Various projects including writing for various motoring magazines and instructing at Murcott's Advanced driving centre. Set up and ran an advanced driving program for the Linfox Australian Automotive Research Centre at Anglesea, Victoria.

1993 Accepted the position of organizer of the Australian sector of a re-run of the 1968 London-Sydney marathon rally sponsored by UK finance company Lombard and directed by UK entrepreneur Nick Brittan. Planned and organized the Australian leg

of the event. Accompanied the event from London – India before returning to Australia to supervise the Australian leg.

1994 Continued writing for automotive magazines including Auto Action, Car Australia and Which Car.

1994-1995 Organised the Mobil 1 Trial, a round Australia event sponsored by Mobil to celebrate its centenary in Australia. The event ran for three weeks, was 20,000 kms long and drew 135 entries.

1995 Accepted a contract position at Holden Engine Company to reorganize its prototype engine building department.

1997 Accepted position as Chassis Section engineer with a new Holden division, Asia Pacific Engineering (APE). Supervised chassis engineering of Opel products for countries in the Asia Pacific area.

1999-2000 Worked on GM China car project for Holden's APE, setting out vehicle performance and engineering specifications including meeting China design rules.

2000 Resigned as APE Chassis engineer to make room for younger engineers. Accepted a contract position in Holden's mainstream Chassis design area to complete the ride and handling development of a revised rear suspension design with toe control links for the VX11 model.

2001 Joined a new Holden engineering group to work on first Australian designed AWD vehicle, the Holden Adventra. Was responsible for development of all chassis components including a new design front sub frame and suspension, revised brakes, power steering, unique tyres, and a new traction control system. Also assisted the TWR engineering group on ride and handling development of the new one tonner and Crewman vehicles.

2003 Finished the Holden contract at the start of production of Adventra.

2007-2008 Organised and directed the Red Centre to Gold Coast Trial, a round Australia type event for historic and classic rally cars. Alice Springs to Gold Coast, length 7500 kms, 70 entries.

Motorsport History

I became interested in motor sport after reading books written by Stirling Moss (Stirling Moss's Book of Motor Sport, 1 and 2), and seeing cars starting the first Redex Trial in Sydney in 1953. The sight of the huge field of rally cars covered in advertising stickers and about to embark upon

a huge adventure driving around Australia kindled an interest in rallying that has lasted 55 years and shows no sign of abating.

At age 15 I purchased an Austin Seven for £17.10.0 and with the help of my father towed it home and pulled it to pieces. Having no money, I reassembled everything as it was, and used the car in "chassis" form to compete in motorkhanas and autocrosses run by the Austin Seven Club of Victoria. I built an aluminium sports body for the car with my father's help, and had the car registered the day after I obtained my driving license (which was on my 18th birthday). This meant I could compete in navigation trials run by the club, but I soon became aware that the Austin, although an incred-



ible little car, was not suited for serious car rallies. Foolishly I stuck with the marque and purchased an Austin A30, which was almost as unsuited for rallying as the Seven.

Working at Holdens, obviously one of their products would be more realistic to own, so I bought a 48/215, black, suspected ex taxi. In this car I tackled some higher level events, navigating for a Holden colleague, Marc McInnes. At that stage I merely wanted to compete, and had no great aspirations to become a great driver or navigator.

Holdens had an attractive employee purchase system for new cars, so my next investment was a brand new 1962 EJ Holden. This car did a season of rallying including

some championship events, using various navigators from the GMH Motoring club.

The much faster EH model with 179 cu in engine was released in 1963 and I bought one. I had settled with a permanent navigator, Jim McAuliffe, who also purchased an EH 179, and we ran most Victorian championship events in 1963 in his or my car, with mostly unimpressive results. Ford was running a strong factory rally team in the same events with the top crews of the time so success was unlikely, but at least we were showing the flag for Holden.

In 1964 Holden initiated a full time rally team to counter Ford's rally successes and advertising. The Holden cars were run under dealer's names, as GM world wide had an official "no motorsport" policy. One of the team cars, nominally entered by Preston Motors, was allocated to the GMH Motoring club, and myself and Jim McAuliffe were allocated the car. Success soon followed, as we won our first Victorian championship event, the Akademos Rally in 1964. In spite of some individual successes for the Holden team in 1965, Ford were still winning the major events such as the Victorian Championship, the BP Rally of South Eastern Australia and the prestigious Alpine Rally.

Things turned around dramatically in 1966, when our team mates Tony Roberts and Peter Haas (all of us Holden employees) won the trifecta: the BP Rally, the Alpine Rally and the Victorian Championship. Jim McAuliffe and I had a bad year, having several crashes in the evil handling HD model.

At the end of 1966 I decided to take a sabbatical, and went to the UK to work at Vauxhall for twelve months. Veteran sports car racer Ron Phillips took my seat beside McAuliffe in the HR model, but again the Victorian championship eluded them. I returned to Australia in time to compete in the Alpine Rally in a spare HR rally car, and despite losing third gear in the Opel gearbox managed to finish third.

1968 saw a long awaited turn around in fortune for McAuliffe and myself. The Holden team rallied HK V8 models with two speed automatic transmissions. Ford had reduced its rally involvement, so we only had our team mates, Tony Roberts and Mike Osborne, to beat. We won five of the championship rounds and finished second in the sixth, giving us our long awaited Victorian Championship. Our car lost a wheel in the Alpine Rally and Roberts had an unlikely win in a Brabham Torana.

At the end of 1968 Holden closed down its rally program, following Ford into long distance touring car racing using the Monaro GTS 327. I was involved closely in the development of the GTS 327 into a racing car as part of my work in the Experimental Department at Holden, and Tony Roberts was keen to purchase one to go track racing, so I was pleased when he invited me as co-driver. I felt my knowledge of the car would make a good contribution.

Being racing novices, we had to obtain a full racing license to race at Bathurst, our ultimate aim. We planned three race meetings before Bathurst, sufficient to obtain our full licenses barring any incidents. Our first meeting was at Hume Weir circuit at Albury, where we ran a Toyota Corolla borrowed from Brian Sampson. I managed to win a handicap race, which was a big thrill. We then took the Monaro to Mallala in South Australia and had a trouble free meeting there.

The Sandown 3 hour race was our next target, but in the meantime we discovered on checking the CAMS Manual of Motor Sport that no long distance records had been set for the Monaro's class. We hired the Sandown track two weeks before the three hour race and set some distance records to gain publicity and hopefully sponsorship for the major races. We obtained fuel and tyre sponsorship and ran the Monaro around Sandown for 24 hours non stop (apart from refuels, driver changes etc), setting 16 new records for the CAMS book. This exercise gave us invaluable knowledge of tyre and brake wear rates on the Monaro, which would stand us in good stead for the Sandown three hour race.

In the Datsun Three Hour Trophy race two weeks later, our first race in the big time, Tony qualified the car 5th, and took the first driving stint. Other Monaros experienced brake problems due to excessive wear of the rear linings, a problem we had experienced and rectified during the record run. At the compulsory refuel/driver change, we decided not to change the front brake pads while all of the other Monaros did. This put us into third place behind the Porsche of Alan Hamilton and Brian Foley's Alfa Romeo, but Hamilton's co-driver was well off the pace, and the Alfa broke a front wheel at Dandenong Road corner.

We were winning. Then, with ten or so laps to go, the brake pedal went rock hard under my right foot, and there was no retardation. I carried on, as stopping would

certainly cost us the race. I was slower by around 8 seconds per lap with no brakes, and the second car, a Monaro driven by soon to be F1 World Champion Alan Jones, was gaining steadily by that amount. Fortunately we made it, winning by 8 seconds. One more lap may have cost us the race.

We ran at Bathurst in 1968, a private entry pitted against factory teams from Ford and Holden. With \$200 sponsorship from Holden dealer Cullens of Liverpool and fuel and oil support from BP, we finished third outright, for a total outlay of around \$2000.

When the 1969 rally season loomed, the former Holden crews were without vehicles to drive. I was approached by Renault Australia to drive a Renault R16, which I accepted. Tony Roberts snared the factory Porsche from the 1968 London to Sydney marathon, so McAuliffe and I did not fancy our chances too much. Surprisingly the Renault was better than we expected, and with some mechanical and navigation problems for the Porsche, we won our second Victorian Championship. Renault was extremely pleased.

For 1970 Renault decided on an all out attack on the Australian Rally championship inaugurated in 1968. The cars were R8 Gordinis, very successful in Europe, but yet to be proven in Australia. With 130 horsepower from the 1.3 litre engine, superb traction due to the rear engine, and four wheel disc brakes the cars were exceptionally fast, and very well prepared by Renault expert Bruce Collier in Sydney. We ran away from Harry Firth's newly formed Holden Dealer Team Monaros and XU1s driven by top drivers including Colin Bond, Tony Roberts, Frank Kilfoyle and John Keran. McAuliffe and I won four of the five heats and were second in the other. We also had an easy win in the Victorian Championship, with very little opposition. Jim and I had won ten championship events in one season.

An inevitable effect of our success over the HDT was that my job at Holdens was put in jeopardy. Come mid year, the ultimatum was put: stop rallying with Renault or lose your job. I asked why I could not join the new HDT, but was told that was not an option for Holden employees. Fortunately I had covered my bets with Renault, and left Holden to become Rally Competition Manager at Renault. Jim chose to stay at Holden so our very successful partnership was brought to an end.

The 1971 Australian Championship

season started well, with an easy win in the first heat. However a series of component failures in the limited slip differentials of the cars cost us several DNF's and we could only finish second in the championship.

As well as dominating rallies in 1970, we entered the new sport of rallycross, The format was four cars racing together over a



circuit which was partly tarmac and partly dirt, with a few water splashes and jumps to add some action. Rallycross became very popular, and was televised live from Calder raceway for three hours on Sunday afternoon, so it was great value for the sponsors, Coca Cola. We built a lightweight Renault R8 Gordini to compete against ex marathon Porsches, Peter Brock's supercharged Torana XU1, hot Minis and a lightweight Ford Lotus Cortina driven by Allan Moffat. The little R8 won outright at the first meeting, and several times thereafter. Similar meetings were held at the old Catalina Park race circuit at Katoomba in NSW, and I managed to win the first event there too.

During 1972 some exciting things happened. Renault decided to enter a car in one of the world's toughest rallies, the East African Safari. We would use an R12 Gordini, one of the five sent to Australia for the 1972 rally year. The car was prepared and shipped to Dar-es-Salaam in Tanzania for the start of the rally. Two other Aussie crews (Evan Green/George Shephard and Stewart McLeod/Peter Huth), both in XU1 Toranas, were also entered. Unfortunately we crashed out early in the event, but we did outlast the two Toranas.

In 1972 Renault Australia also wanted to push sales of the Peugeot 504, and entered a standard car in the demanding 2500 km BP Rally. My navigator was Geoff Thomas, very experienced in this particular rally, and with his excellent navigation and the car running comfortably and reliably we won the event. Renault, needless to say, was ecstatic. We followed this up with a win in the very difficult Experts Trial in the same car.

In 1973 Renault, through a combination of failing sales and lack of a competitive rally car, stopped its rally operations, so I joined Bendix Automotive as their resident engineer at Holden. In the meantime Jeff Beaumont and I had scored some points towards the Victorian Championship early in the season, so I approached Harry Firth to supply us with a car to continue the championship. Standing idle was a HQ Kingswood V8 that had been built for Peter Brock to run in the Hattah desert rally, so we did a deal. The Kingswood was a great car and we went on to win several events and take the Victorian Championship again.

At the end of 1973 I was offered a drive



in the Southern Cross Rally in a factory Datsun 240Z, navigated by Jeff Beaumont. Datsun, (Nissan) were desperately trying to win the Southern Cross event because it provided good advertising in Asia, but they were frustrated by Andrew Cowan's invincible Mitsubishi Lancer. We had a strong team with Rauno Aaltonen, Tony Fall, East African Safari winner Shekhar Mehta, Frank Kilfoyle and myself, but Cowan won again. It was a tough wet event and we finished eighth of the nine cars that completed the entire course.

At the start of the 1974 season Datsun Competition Manager Bruce Wilkinson offered Jeff and I the Datsun 180B SSS that Kilfoyle had driven in the previous Southern Cross. It was a good car and we had a promising start in the first Victorian event. Then a wild card appeared, in the form of a world championship winning Renault Alpine A110, imported by Renault for shows and dealer displays. I was offered the car to drive in a new rally, the Don Capasco, to be run in the forests around Canberra in true European style. This was a golden opportunity, although Wilkinson did not agree and Jeff and I were ousted from the Datsun team. We won the Don Capasco (later Castrol) Rally very easily against strong opposition. The car was superb. The Alpine A110 was also entered for the 1974 Southern Cross Rally, but small mechanical problems and a

failed ignition coil caused the car to DNF.

1975 saw another change of rally car marque. Although temporarily out of motor racing, Ford Motor Company had imported an ex factory Mark 1 Escort BDA rally car to be run privately by Howard Marsden. The car was left hand drive, and the navigator was Jeff Beaumont. First event was the 1975 Don Capasco Rally. The Escort was very fast, but drowned the ignition system in creek crossings, which meant numerous delays. While trying hard to make up time the rear suspension was damaged and the car retired.

The Escort was run in a number of Australian championship events, but dust entry into the engine during the first rally meant an engine rebuild was required and subsequently the engine was well down on power. A few minor placings were achieved but the true potential of the car was never realized.

There was no rally program for me in 1976. Our son Daniel was born, and spare time was spent on renovations to our Elwood house. I did build a Renault engined off road buggy so that I could get a taste of off roading, and competed in a couple of desert rallies, but when I gained a rally drive



for 1977 the project was shelved.

For 1977 I was offered a drive with the Canberra based Gerry Ball Rally team. Former team driver Greg Carr had joined the official Ford team, but his navigator Wayne Gregson elected to stay with the Ball team and navigate for me. We ran a highly modified Datsun 120Y, finishing second in the Castrol Rally. A series of mechanical failures caused DNFs in early events and the priority for the season then shifted to the Singapore Airlines London to Sydney marathon event, in which Gerry Ball was also a competitor.

I was offered the position of team manager for a team of privately entered Peugeot 504s for the Marathon. The private entrants would buy the basic cars which would then be rally prepared by the Peugeot competition department in France. However indus-

trial problems at Peugeot France meant that the cars and the parts to prepare them were hastily shipped to London, where the team members and Peugeot UK mechanics had to prepare the cars.

The cars were prepared in time for the start, but unfortunately the Peugeot 504 wagon entered as a mobile service car for the team and driven by accomplished rally driver/mechanic Gil Davis crashed in eastern Turkey. The three team cars reached Australia well placed, but one crashed and one suffered overheating, leaving the



remaining Dunkerton/Watson/Bonhomme car to finish 5th outright, first in class and first all Australian crew.

1977 finished with two more events for the Gerry Ball team. For the Southern Cross Rally the team ran a Datsun P 710 Violet single cam loaned by Nissan. The car was built up from various left over parts from the Nissan competition department. I had a new navigator Peter Godden, who was excellent, and with heavy attrition in the field we finished 3rd outright and first Australian crew, behind two internationals, Rauno Aaltonen and Harry Kallstrom.

The final event for 1977 was the Alpine Rally. The Gerry Ball team ran a Datsun P 210, loaned by Nissan, a factory car which had been used in the Southern Cross rally by Shekhar Mehta. The car held third position behind the Escorts of Carr and Bond for most of the rally, and moved into the lead when the Escorts struck problems. With 30 kms to go and leading, the flywheel failed leaving the Datsun with no drive. 36 tyres were used during the event.

1978 saw a pause in rally activities as Bob Watson's Service Centre was established in Hawthorn Victoria in partnership with Bruce Shepherd. Initially all efforts were put into making the business a success but as the client base increased I felt there was an opportunity to go rallying again. Renault Australia agreed to let us use the ex Singapore Airlines marathon car for the Victorian Championship, although no financial support was provided.

We had Graeme Ritter turbocharge the car to make it competitive, and it was ready



Application for Membership

Ballarat Light Car Club

Incorporated (Certificate of Incorporation Number A20023019V)
P.O.Box 400 Ballarat, Vic, 3353

Dear Sir/Madam

I,
 Mr _____ (Surname) _____ (Given Names in Full)
 Mrs _____
 Miss _____
 Ms _____

of _____ (Postal Address) _____ (Town / Suburb) _____ (Post Code)

Telephones - Private: _____ Business: _____ Mobile: _____

Email Address: _____ @ _____ DOB: _____

desire an ORDINARY FAMILY ASSOCIATE FAMILY ASSOCIATE PARENT ASSOCIATE COUPLE
 membership of the Ballarat Light Car Club and agree, if elected, to be bound by the rules and bylaws of the club.
 (mark the applicable category of membership)

Current Fees (01/07/11)

Category	Nomination	Annual
Ordinary	\$25.00	\$90.00
Family	\$25.00	\$120.00 (2 Adults, any number of own Children up to 17y.o)
Associate Family	nil	\$83.00 (2 non-competing Adults, 1 competing child)
Associate Parent	nil	\$58.00 (Parent/Guardian, 1 Child competing)
Associate Couple	nil	\$50.00 (2 non competing adults)

I enclose membership of \$ _____ I have paid via direct deposit to BSB 630-000 Acn 141857458 (please include name and member number)

Occupation / Employer: _____

Names of Family Members: Partner: _____ Child 1: _____ Child 2: _____

Child 3: _____ Child 4: _____

Type of vehicle/s that you will use to compete: Make: _____ Model: _____

I would like to receive my BULLETIN electronically at my email address above: _____

Signature: _____ Date: _____

Please fill in all details and attach appropriate fees when submitting this form

We, the undersigned, being members of the Ballarat Light Car Club, wish to recommend acceptance of the above application of the above application for membership. The above named candidate is personally known to us and we believe him/her to be a suitable person to be elected a member of the Ballarat Light Car Club Inc.

Proposer: _____ Signature: _____ Member No. _____

Seconder: _____ Signature: _____ Member No. _____

Office Use Only	
Received: / / 20	
Fees \$.....	
Received	<input type="checkbox"/>
Welcome Letter	<input type="checkbox"/>
Member Number	
Completed	<input type="checkbox"/>



If undeliverable return to
Ballarat Light Car Club
PO Box 400
Ballarat Vic 3353

**PRINT
POST**
PP325876/00031

**POSTAGE
PAID
AUSTRALIA**

The Bulletin

Print Post Approved

