



WHAT'S INSIDE:



Noel Peers President
report
PAGE 3



Calendar of Events
BLCC
Results :-
CSA Mt Leura
Autocross Rnd2
+ More
PAGE 6



History Slice.
PAGE 14

May 2011

The Bulletin

The Official Publication of the Ballarat Light Car Club

Notice of 2011

AGM

ANNUAL GENERAL MEETING

Winter Classic Looking forward to this years event - we are looking for a crew to organise this years event. Please contact a committee if you are interested. More Info page 13

Competition Numbers On request, the AMRC has recently re-visited their policy on variations to the regulations on Competition Numbers on vehicles. Following discussion, the AMRC confirms their position

that the Competition Number on the vehicle is a "tool" for the better management of racing and not merely a promotional tool for competitors The regulations prevent the use of triple numbers at national events, and also on the

use of numbers starting with zero. Both these uses of numbers has the potential to create confusion in identification with timekeepers, and also with officials reporting problems or incidents with a particular car and thus are not

Continued page 10



Committee 2010 - 11

The Bulletin

A monthly newsletter of the
Ballarat Light Car Club

Editor: Steve Ezzy

E-Mail: blcceditor@hotmail.com

Mob: 0400 160 158

Contribute: Contributions can be emailed or posted to 1014 Ring Road Ballarat

Deadline: 7 pm Thursday, 8 days prior to monthly club meeting.

Website Info



<http://blcc.net.au/>

Webmaster: Wayne Sleep

AH: 5339 4890

Mobile: 0419 031 712

E-Mail: blccwebmaster@hotmail.com

President

Noel Peers
Property Officer
AH: 5341 8124
Mob: 0408 033 895
blccpresident@hotmail.com



Secretary

(Currently vacant)
Mob:
blccsecretary@hotmail.com

Treasurer

Clare Bennett
AH: 5330 2295
Mob: 0439 652 325
bennett@ncable.net.au



Grants Officer

Assistant Media Liaison
Officer
Stacey Noonan
Mob: 0417 163 193
staceynoonan@hotmail.com



Events Secretary

C.A.M.S Liaison
Sport Sub
Committee Chair
Rod Hall
53313546
0438 313 546
rod.hall@ballarat.edu.au



Sports Sub Committee

Ben McGee
Barney Haddon
0437 167 790 / 5335 5112
Damian Faulkner
0407 643 803

CAMS

Sports Club Development Officer
Rob Dunt / 9593 7740

Permits Administrator
David Milne / 9593 7732

Vice President



State Council Rep
Les Noonan
AH: 5331 6148
Mob: 0410 524 139

Membership Secretary

w.sanders@optusnet.com.au
Wayne Sanders
AH: 5334 2330
Mob: 0412 713023



House Chairman



M/sport Cplx Manager
Assistant Property Officer
Hillclimb Panel Rep
Barney Haddon
AH: 5335 5112
Mob: 0437 167 790
barno4@bigpond.net.au

CAMS State, AASA

Delegate

Ian Brain
Mob: 0418 518 088
ibrain@ncable.net.au



Bulletin Editor



Steve Ezzy
AH: 5339 4821
Mob: 0400 160 158
blcceditor@hotmail.com

Positions Currently Vacant

Rally Panel Representative

JDP Co-ordinator

Sponsorship

Presidents Report May 2011

G'day and welcome to the May issue of BLCC's Bulletin.

This last month has flown by real quickly! Here I am trying to knock a report up, you seem to get a little out of touch when you miss an event. I missed the last autocross on the 1st of May. This event was supposed to be a round of CVAC but wasn't

This will have to be looked at, as I stress that this my opinion only at this stage - I think we are flogging a dead horse, gee we have been trying to organise this for well over twelve months. I seem to remember hearing this will definitely happen in 2011, well its May and it still hasn't happened!.

Sunday sees Autocross round 4 taking place, sorry I will be an apology due to work commitments. I will also be an apology for the May meeting so Les will be kindly chair it for me as I will be scrutineering at the Winton Historics along with Chris Hall and Paul Duncalf. Chris and I

have been officiating at this meeting for at least a decade, he has done it one or two more times than me.

The next event on the radar is the Motorkhana and Khanacross event on Sunday 5th of June. At the same time as this Ararat are running their hillclimb, I haven't heard anything about this so I can only assume that they are all under control.

Also on the club front thanks to Barney and the kids and one of their mates we made a long overdue start on some of the chores around the club.

Its that time of year soon when memberships are due, so start paying from now as they fall due at the end of June. Our AGM is also coming up in July so keep an ear out for more info. There will also be some vacancies on committee as the normal cycle takes effect. If you are interested in being on the committee please think about nominating and start to have a say in improving or running 'your' club. One position



'secretary' is vacant as Ange Rugg has had to resign because she works at the RTA and works on the CH plate system. Her superiors deciding that this was a conflict of interest. We thank her for her contributions to the club and committee. Thanks to all those who competed in the last Autocross and the one on Sunday - Have fun and I hope to see you soon 'have fun!'

Noel Peers
President

Treasurers Report May 2011

Hi all,

April/May to date has been basically been catching up. The accounts have been submitted for the BAS but have not signed off yet but I am pretty sure we will be paying due to some overhangs from the last quarter and the Mt Leura Hill Climb.

The Club can expect some payment for the Festival of Motorsport but this has not been finalised. Thanks to all those who gave their time, skills and knowledge both before, during and after Easter Sunday. It was a fantastic day showcasing motorsport. I know many of you had families that missed you on that day because you were helping out.

The Autocross May 1 saw 33 adult and 3 junior entries to the value of \$1380 and the Junior Training had 3 participants. We hope to grow the junior experiences more through the generosity of people like Mark Hunter so please support this program to grow our young drivers.

Over the next month I will be focusing on end of financial year matters and hope to purchase our new stove for the kitchen so we are able to suitably cater for events. We will need the talents of a carpenter/handyman to create a bit more space for it though.

Catch you soon,

Clare Bennett (Treasurer BLCC 2010-2011)



Pay your membership from anywhere!!
Ballarat Light Car Club banking details
BSB No: 633-000
Account No: 141857458

Homologation of Parts within WRC or FIA Regional Rally Championships

The FIA have recently announced that National competitors contesting events of the World Rally Championship or FIA Regional Championships within their region may use alternative parts to those homologated provided that the part is of similar design, not less in weight and gives no competitive advantage. This will of course include Rally Australia upon its return in 2011 and this year's International Rally of Queensland, an Asia Pacific Rally Championship event. The objective is both to reduce costs and increase participation.

Any alternate parts will need to be authorised by the relevant ASN (in this case CAMS) which in turn is required to advise the FIA of the parts that are authorised. The FIA suggests bumpers, front air splitters, brake discs, clutch plates and 'similar' as examples of components that could be considered.

This step has been taken by the FIA in recognition of the costs of some



homologated components which would need to be fitted to restore eligibility of a given car to FIA Group N or A specification, particularly when they would not otherwise be required in national competition classes.

A number of competitors who would otherwise not be able to compete due to ineligible components may be able to reconsider their entry into the international section of these events as a result of this provision.

It should be noted that this applies only to vehicles homologated by the FIA which are eligible for the events in question.

Competitors wishing to pursue this option are requested to contact the CAMS Technical Department.

Proposed **BLCC Book**

In the last 18 months a dedicated group of members have been working on documenting, copying, collating and recording a tremendous amount of material related to the history of our club. They have met regularly with past members and now have the basis for the creation of a valuable historical book covering the 60 years of our clubs existence.

The principle members of this group have now put out the call for people that may be able to contribute to publication by way of volunteering to complete the sorting of this material which is in an electronic form and physical documents, and the publication of the various sections, ie decades and specialist Motorsport areas, people with experience in IT would also be very useful, however any assistance would be gratefully accepted.



Update – Impact Racing SFI Certification



The SFI has released a statement which updates the status of the decertification of certain Impact Racing products previously certified to SFI Quality Assurance Specifications 3.2A (driver suits), 3.3 (gloves, underclothing, hoods, socks, shoes, boots, helmet supports, harness pads and arm restraints), 16.1 (driver restraint assemblies/harnesses) and 16.5 (stock car driver restraint assemblies).

The release follows in its entirety:

April 21, 2010 – SFI issues the following press release. Please review this carefully:

1. Impact Racing has withdrawn its appeal of the decertifications of its products bearing SFI 3.2A, 3.3, 16.1, and 16.5 specifications manufactured in the years 2005, 2006, 2007, and 2008. The decertifications of these products are now permanent.

2. The decertifications are based upon a number of the affected products being noncompliant with SFI specifications concerning labeling and construction. In addition to the presence of non-compliant SFI tags and the absence of DOMs on products, 3.2A/5 suits made prior to 2009 have been constructed with non-compliant materials that, in

SFI's judgment, pose a safety risk to users of these suits.

3. Impact Racing is permitted to maintain the certification for products bearing SFI 3.2A, 3.3, 16.1, and 16.5 specifications manufactured in 2009 and 2010. SFI's investigation of the labeling and construction of these products is ongoing. Impact's participation in the SFI specification programs ends June 22, 2010.

4. Any Impact product with SFI specifications 3.2A, 3.3, 16.1, and 16.5 without a date of manufacture (DOM) is deemed to be a decertified product unless the manufacturer has provided the product user with proof that it was manufactured in 2009 or 2010. This proof must be presented to track officials upon request. Impact believes that its products made in 2009 and 2010 have the DOMs affixed to products to the extent mandated by SFI specifications.

This is an ongoing issue and further information &/or updates may be obtained direct from the SFI web site: www.sfi-foundation.com

CAMS recognises a number of SFI standards for use in various competitions, including some in

respect to apparel and harnesses which would be subject of the SFI decision. Please be aware that where compliance with one of these standards is mandated (refer to Schedule D and Schedule I of the CAMS Manual of Motor Sport for full details), a decertified product cannot be used in competition and will need to be replaced with a compliant one.

If you have an Impact Racing product which is captured by the decertification outlined in the SFI press release, CAMS recommends that you contact the retailer that supplied the product or the manufacturer for their advice. It is understood that helmets produced by Impact Racing are certified to the Snell Memorial Foundation standard and are therefore not subject of this action by the SFI.

Note: The SFI Foundation Inc is a USA based not for profit organisation established "to issue and administer standards for specialty/performance automotive and racing equipment" (quoted from SFI's web site).

Event Calendar



■ May

Sunday 1st

Central Victorian Autocross Challenge
round 2 Ballarat (AX3)
CSA Wheels Victorian Hillclimb
Championship Round 4 PIARC

Saturday 14th

East Gippsland Stages VRC1

Sunday 15th

Geelong AX/KX R3 - Autocross

Saturday 21st

The Italian Connection

Sunday 22nd

BLCC Autocross Round 4 CDC3

Friday 27th

BLCC Club Meeting

Saturday 28th

The Ken Roddnam Memorial Trial

■ June

Saturday 4th

Daryl Tunbridge Trial

Sunday 5th

BLCC Motorkhana 1 and Khanacross
Victorian Hillclimb Championship
Round 5, Ararat

Sunday 12th

Bega Valley Rally VRC2

Saturday 18th

Seemore Stages 2,

Sunday 19th

Winton Sprints CDC4

Friday 24th

BLCC Club Meeting
Saturday 25th
Nissan Nightmoves CTS3, VCRS 2

Sunday 19th

Geelong AX/KX R4 - khanacross

■ July

Saturday 2nd

Kelly Country Trial, HRA
BLCC Motorkhana 2 CDC5 and Day
Night Autocross

Sunday 3rd

CSA Wheels Victorian Hillclimb
Championship Round 3 Shepparton.

Saturday 16th

George Derrick Memorial Rally VRC3 -
CTS4

Sunday 17th

Geelong AX/KX R5 - Autocross

Sunday 24th

BLCC, Barney's Double Banger Autocross

Friday 29th

BLCC Club Meeting

Saturday 30th

Rich River Revisited, HRA

■ August

Saturday 6th

Baden Powell Introductory Trial Rover
Scout Motorsport

Sunday 7th

BLCC, Motorkhana 3

Saturday 13th

Cooper Memorial Rally Sprint

Sunday 21st

Geelong AX/KX R6- khanacross

Friday 26th

Winter Classic Rally and Tour
No Club Meeting

Saturday 27th

Winter Classic Rally and Tour
Ivans Folly

Sunday 28th

Winter Classic Rally and Tour
Victorian Hillclimb Championship
Round 7, Haunted Hills

■ September

Saturday 3rd

Mt Porpunkah Rally Spring
The Lions Rally

Saturday 10th

Mafeking Mahem

Sunday 11th

BLCC, Motorkhana 4 CDC6
Geelong Motorkhana R1

Saturday 17th

Marysville Stages, VCRS Round 4, CTS6

Sunday 18th

CSA Wheels Victorian Hillclimb
Championship Round 8 Rob Roy
Geelong AX/KX R7 - Autocross

Friday 30th

BLCC Club Meeting

■ October

Friday 7th

Bathurst 1000

Saturday 8th

Wild Dog Stages CTS7
Bathurst 1000

Sunday 9th

Bathurst 1000
Proposed BBQ and Bathurst day at
BLCC Clubrooms. (register your interest
bathurst2011@blcc.net.au)

Saturday 15th

Akademos VRC4

Sunday 16th

Sandown Sprint CDC8
Geelong AX/KX R8 - khanacross

Friday 28th

BLCC Club Meeting

Saturday 29th

Bagshot Rallysprint

■ November

Saturday 5th

Coghlan's Carnival

Sunday 6th

Coghlan's Carnival
Geelong Motorkhana R2

Saturday 12th

Rally Victoria

Sunday 20th

Reserve Date for BLCC Autocross and
Series
Geelong AX/KX R9 - Autocross

Friday 25th

BLCC Club Meeting

Saturday 26th

Alpine Rally

■ December

Saturday 3rd

Ararat One Tree Hillclimb

Sunday 4th

Ararat One Tree Hillclimb

Sunday 11th

Geordie Fawcett Memorial Autocross,
Xmas Breakup
Geelong Come & try khanacross

Notice to Bulletin Advertisers

If you wish to place an advertisement, please consult the Treasurer, **Clair Bennett** (5330 2295 or 0439 652 325) who will arrange an invoice and pass the request to the Editor, **Steve Ezzy**, for inclusion in the appropriate issues.

Please see the table below for the Annual Fee for Advertising

Size	Annual Fee (\$)	1 Month Fee (\$)
Full Page	220	22
Half Page	143	14.30
Third Page	119	11.90
Quarter page	99	9.90
Sixth Page	89	8.90
Eighth page	79	7.90

Member Small adverts of the Buy, swap & Sell type will continue to be **Free**

Club Scrutineers

Chris Hall	Grade 2	5342 4397 0438 094 684
Noel Peers	Grade 3	5341 8124
Darren Wythe	Grade 3	0448 417 506
Ben McKee	Grade 3	5336 1172 0418 313 695
Wayne Webb	Grade 3	5334 7698

Your Club Get Involved

Doing it for the club

There are often tasks that need completing or some work that needs to be done around the club. More often however we are a time poor lot and there are many other things going on (many hands make light work).

This does not have to mean that there is nothing that you can do for the club. Many of us have skills that are useful and can be easily utilised. Computer or IT skills, communications, design, carpentry, driver training fund-raising you name it there is always at some time or another something useful that you can do that does not involve actually doing car stuff. So if you can only cook one barby in a year or do up a page for the Bulletin, service a JDP car or deliver phone books we will value your contribution.

Editorial

I have had a wonderful weekend and I enjoyed the company of our members (new & old) at our recent Autocross. What I see at these events is the camaradery and mateship that I miss. The friendly time results watching and the back slapping, and the rapid intakes of air as the passing cars on the track get all out of shape. It is really something and despite the big dump of rain and the sloppy surrounds and track people seemed content to enjoy themselves.

I would say that the event was a success, due in no small part to the members that give their time to ensure it. One person that I would like to make a special point of thanking is Paige Haddon who work in the cook house all day, not only bring and eating her

own lunch but thanked me for letting her help. I would also like to thank our director for the day Ian Brain who not only ran the day but provided us with the Soup de sur. Ian has also been responsible for coaxing me out onto the track, providing me with both a vehicle and helmet which meant all of my excuses were expired.

It would be nice if we had a good turnout for the AGM this year so now would be a good time to pencil it in to your calendar, you have a month and a bit.

Another thing that you might like to consider is putting your hat into the ring and become a member of the committee. I have been on the committee for about eight years and like to be able to make a contribution that achieves positive outcomes. So give it some thought and nominate



autoparts

PROFESSIONALS
BALLARAT

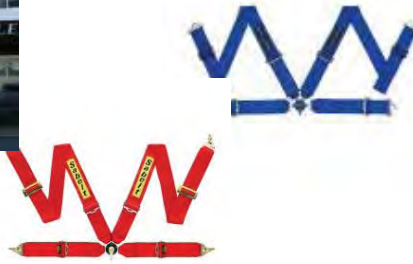

3" RPM Harness FIA Approved 4PT **Red**, **Silver**, **Black**, **Blue** \$249
 3" RPM Harness FIA Approved 6PT **Red**, **Silver**, **Black**, **Blue** \$269
 2" RPM Harness AS2596 4PT **Red**, **Black**, **Blue** \$195



Willans Harnesses also now available in **Silver**, **Red**, **Blue** and **Black** \$399



SaBelt 4pt Harness, **Red**, \$445



Sparco PRO ADV Raceseat, \$1395 **IN STOCK!**

Spacro EVO Raceseat \$1099 **IN STOCK!**

Cobra Monaco Raceseat FIA \$495 **IN STOCK!**

KIRKEY Alloy seats from \$269 **IN STOCK!**

JAZ/RPM Plastic Seats from \$119 **IN STOCK!**



RPM Helmets, Best seller for 2009!

RPM Rally Open Face \$399

RPM REV-1 Full Face \$499

RPM PUMPED Force Air \$699

All SA 2005 Approved, Lightweight Composite Shell, Kevlar Strap and Nomex lining, Great value, HANS Ready, all in stock!

BELL Helmets also stocked starting from \$799

HANS Device from \$950 in stock!



RPM Clubsport Single Layer Suit \$299

RPM Club Gloves \$89

RPM Mondial Double Layer FIA Suit \$699

Packages starting from \$849

Mechanics Gloves from \$29.95

Call in and see Nathan and David, for there huge range of stock, 7 days a week, for friendly advise and great prices, supporting the Ballarat light car club for 15 years!

Auto Parts Professionals, 9 Doveton St Nth, Ballarat, 53329333

News in Brief *continued*

permitted. For the same reasons, the size and type of numbers used is regulated and must be complied with. However, provided that the numbers are clear and easily identified, variation to the standard sizes is permitted for specific categories on application. The AMRC noted that there is ample scope on the rest of a vehicle to feature numbers integral to promotional and sponsorship needs.

Club Historian

The committee is calling for expressions of interest from persons interested in becoming the club historian.

Log Books

All competing cars must present with either a "Club" log book or one issued by CAMS.

Good News

CAMS now permit you to use FAI approved seat belts with "valid to" dates for a further 5 years. For example "Valid To December 2008" can be used up to December 2013.

Club Points Compiler

We are **still** searching for someone to take on the role of Club Points Compiler. If you are interested in filling this position please contact a committee member. Please note if someone does not step up to fill this position the CDC etc will go un-scored this means no trophies.

Western Link Road

The Ballarat Western Link Road would connect the Western Highway near the Ballarat Airport and the Midland Highway to the south of Sebastopol. It would serve new developments at the Airport precinct and residential developments in Ballarat West and would be approximately 16 kilometres long. Recent studies have identified a preferred alignment that is two lanes wide in each direction from Glenelg Highway to the Western Highway in the north, and one lane wide in each direction from Glenelg Highway to Midland Highway in the south. However, transport modelling has shown that the ultimate road configuration as described above would not be required until 2031.

ROBSON GLASS

Established over 98 years

Shop Fronts



Broken Glass Replacement



24hr Emergency Service



Cut To Size Glass & Glazing



Insurance Work



Lead Lighting



Mirrors



Safety & Sound Proof Glass



Glass Splashbacks



Shower Screens



Double Glazing



W J ROBSON & SONS PTY LTD
5332 2078 MBL 0418 508 429

After Hours 5341 3898 or 5339 4664
Cnr Maun Rd & Humffray St Ballarat



Liability Disclaimer – All material in this magazine represents the opinions of the authors and does not carry any endorsement by the Editor or the Committee, Ballarat Light Car Club has no official connection with any public or commercial organisation and it does not provide product recommendations. Names of commercial products mentioned in this magazine are registered names and trademarks of their owners. Copyright Notice – Material in this magazine may be copied by any other club without fee or written permission provided that the copyright rests with the Ballarat Light Car Club. The copies are not to be used for commercial advantage and the origins of the material and this permission to copy are acknowledged in the reprinted item. The Nissan Car Club-Australia is acknowledged as the source for the wording of this Disclaimer.

Sport Sub Committee **Notes**

BLCC Sports Sub Bulletin Precis May 2011

Trophies are still a work in progress as manufacturer has been working away from home.

Past Events

Seemore Stages reschedule event from April. 55 odd cars fronted the start line which included 5 BLCC crews. Event seemed to run fairly smoothly. 8-10 crews DNF'ed but only 1 had to be extracted by recovery crew. Had much better weather than last year. **Roscoe Stapleton** was the quickest from BLCC. **Steve Wilson** was next keeping his nose in front of **Darren Wythe** and **Chris Hall**.

Myrniong Sprints saw 92 entries front up with 4 BLCC entrants. **Richard Monty** won his class.

Mt Leura – Round 3 of the Victorian Hillclimb Championship. Couple of prangs spoil an otherwise good event with heaps better weather than last year. Some significant improvements have been made by the Camperdown Council with the initiation by Scott Ball. The ambulance guys were particularly thorough. With the improvements made both already and some to be made in the future we as the holders of the track licence need to use the Mountain or Hill more often. To this end we need to be able to get competitors there for an event that isn't a state round. One suggestion that came from our April Clubnight was to run a meeting for Historics. If any one else has any suggestions please talk to us. It would be useful in years to come to have a second hillclimb locally for our CDC.

Airport "Drags", International Race re-enactment. Went very well. Need to diminish delays. Would use 2 finish beams if run again as too many dead heats occurred which slowed the meeting down. Clerk of Course **Damian Faulkner** and his assistant **Russell McKenzie** along with Rod Hall had too much to do on the day. Needed more publicity in the lead up. Debrief yet to happen. Parade went very well and looked great.

Autocross Rd 3 had 36 starters. The regs were very late coming back from CAMS because of Easter holidays etc so the rollup was pretty good. The RFID tags were trialled on 10 of the cars. This has been a while coming. Thanks to **Keith Scott** who managed to procure a supplier in the great manufacturing China (What aint made in China nowadays?). **Rod Hall** had a hand in it as he had to further improve the timing software. Once the sensitivity and location were adjusted they worked very well in all of the cars except 1 which was subsequently found to have no batteries in the tag/card so it wasn't too surprising it didn't work. As we use these facilities at future Auto-crosses we will need to have a no go zone for cards around the tower as the system picks them up at around 70m. Was found to read from the tower to the horse-shoe which is a fairly long way.

Following up on a suggestion from the preceding Friday Clubnight – thanks **Sharon** we tried separating the kids from the pit area by suggesting they be confined to the triangular fenced area between the pits and the track. Could parents make a note of this. We don't want to back out over some-ones little cherub. We will also be taking steps to fence in the play area behind the timing tower now that it seems to be getting more use.

The Introductory Motokhana initiated and run by **Mark Hunter** and **Mark Salter** was well received and patronised. The idea behind Marks initiative is to give those that are too young or inexperienced to compete in an Autocross an activity whilst scrutiny happens to foster their interest and keep them interested. Great initiative guys keep up the good work please.

The VHC round down at Phillip Island has been run and won. **Glenn Latter** and **Richard Monty** both won their classes with **Steve Grinstead** 3rd in class in unfamiliar territory for Grinna.

Coming Events

5th June Motorkhana followed by a Khanacross. **Keith McElroy** and **Ash Findlay** direct the Khanacross. We still need someone to direct the Motorkhana.

Winton Sprint on 19th June is a CDC round and is run by Maserati. Regs are on the Maserati website at www.maserati.org.au/Quick_access.htm

Nissan Nightmoves on 25th June is a round of our Club Trials Championship. See NCCA for regs.

Motorkhana Series Rd 2 and a day/night autocross are both down for the 2nd of July. The MK will happen in the morning and early afternoon before the day nite AX. Directors and Steward needed ASAP. The MK will be a round of the CDC. Given it's a while since we have had daynight AX dust off the Cibies and head out for some fun in the dark and get in some practice before Barney's Double Banga on the 25th July.

The second hillclimb for the CDC will be Rob Roy Hillclimb on 18th September so please mark that in your diaries.

Maserati have also confirmed that the 16th October is their Sandown Sprint which is another round of our CDC.

A query was raised whether the MK and KX on the 5th June should be moved due to being on the same day as ACC's VHC Hillclimb. After considerable discussion it was decided to leave the dates as they are. The Ararat event is not part of any of our series. The calendar is very full already and it would be very difficult to reschedule.



**VICTORIAN HILLCLIMB
CHAMPIONSHIP ROUND 5
ARARAT HILLCLIMB 2011 PRESENTED BY
ARARAT CAR CLUB
SATURDAY 4th & SUNDAY 5th June 2011
Conducted by ARARAT CAR CLUB Inc**

E-mail Notifications.

A new e-mail notification system has been implemented on our site to simplify the process of keeping members and other interested parties informed of goings on in the club.

Sign up to receive event updates and announcements from Ballarat Light Car Club about upcoming events and activities. E-mail announcements will be sent out occasionally about website-related activities and new website features.

Note: this feature is not in place of the electronic send out of the club newsletter. And all recipients of the bulletin should feel free to sign up for notifications.



Proposed Members Business Register

I was pondering how I was going to find someone to complete the removal of a huge amount of Wisteria from my side fence. I considered the phone book for a moment and as I did so I thought about who in the BLCC might know someone from the club who knew someone? I was then prompted to think about the amount of useful information that could be collated into a list of useful business / skills / hobbies that people have, do or run.

To this end I thought I might put my idea out there, I will collect a list of members (proposed to me) of people who are likely to be useful to other members. I do not propose that there be any discounts or freebies just a list of people and their field of expertise.

So, if you make stickers, weld up roll cages, are an expert in suspension, electronics, gardening, office supplies, sell bolts, make trailers, are a retired business man willing to offer advice, are an expert in IT or lay cement than you should be on this list.

If you would like to be on this list (Name, Number and field) then SMS or Phone me Steve Ezzy 0400 160 158 or email blcceditor@hotmail.com

Members listed below have nominated themselves as being willing to assist fellow members

Ian Brain (expert in restorations and pressed metal ceilings)

- 0418 518 088 or 5332 2828

Peter Ellis (Driving Ambition) Driver Training Specialist to Individuals and Business - Mobile 0419 002 007 Tel. (03) 5334 3144



Mechanica Industries

design · create · repair · salvage

- Mechanical engineering
- Automotive maintenance & repairs
- Machine shop
- On-site maintenance

*If its metal, we can design it, create it, repair it or salvage it.
At Mechanica Industries, we love machines!*

Mechanica Industries are located at **12 Paddys Drive Delacombe 3356**

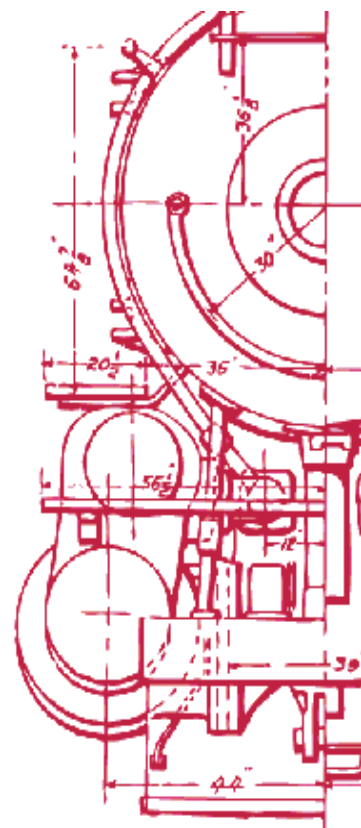

www.mechanicaindustries.com.au

5335 7251

CTC Series Competitors: Early Entry

This year, the general lack of rallies is causing events to fill up fast. To make sure you get a run, you will need to enter quickly when entries open.

The Sport Sub Committee has decided not to remove events from the CTC Series if someone misses out, unless they have entered within 10 days of entries opening for that event and been refused

WEBB ALL TRADES **WEBB SIGNS**

House & Home

- House Renovations & repairs
- Plasterboard Hanging & Finishing
- Floor & Wall Tiling
- Concreting. Shed slabs, path's, driveways
- Tree felling & lopping
- Any size job
- Quality work
- Upholstery coming soon!

Signs & Graphics

- Race & Rally Signage
- Magnetic Signs
- Boards, Banners & A Frames
- Shop front & Business signage

Vehicles

- Competition car preparation, Panel beating & Spray painting
- Welded Rollcages to Cams specs
- General welding (Cert. 8G) & fabrication.

Wayne & Angela Webb
10 Frawleys Rd, Leigh Creek, 3352
PH: 53 347698 OR MOB: 0438 347 698
Email: webballtrades@westnet.com.au

Sport Sub Committee

Rod Hall (Chair) Barney Haddon, Ben McKee, Darren Wythe (Rally Liason), Damian Faulkner, Steven Richards, Wayne Sleep, David Marmo, Peter Marmo, Ben Divis.

Meetings: Wednesday night immediately prior to monthly committee meeting.

Leaving the complex after Scrutineering

If a competition vehicle needs to leave the motor sport complex, you must remove your numbers so the Police or Vic Roads don't nab you. Also the vehicle needs to be re-presented for scrutiny upon its return before continuing competition.

CH and H Plated Cars

From December 1st 20?? A small fee of \$5 will be charged for new and renewal registrations. Chris Hall will collect this when he signs your form. Special use vouchers will also cost \$5. These vouchers must be used when you drive your car for any purpose other

than a BLCC calendared event. The BLCC recently became a member of the Association of Motoring Clubs. The AOMC is working closely with Vicroads on the scheme to introduce a 90 day log book (with a 54 day option). In order to have an input and to be kept informed of the latest

news we needed to join this club. To cover the costs of this membership and the vouchers it has been necessary to impose this small fee. If you have any questions please contact Chris on 5342 4397 or 0438 094 684.

Club Driving Instructors					
John	Bourke	Wayne	Drew	Rod	Hall
Richard	Gay	Gary	Harrowfield	Barney	Haddon
Mick	Goossens	Engels	Leoncini	Peter	Ellis
Les	Liston	Simon	Ellis	Darren	Wythe
Darren	Everett	Ben	McKee	Steve	Richards
Damian	Faulkner	Russell	McKenzie	Mark	Fawcett
Ben	Fawcett	Steve	Wilson	Chris	Hall
Keith	McKelroy	Ben	Davis		

Membership

WELCOME NEW MEMBERS

This month we welcome to the Club.

Clive Howse from Buninyong. Clive will be competing in a Corolla, but i also saw him driving a very smart looking Mini at the last meeting.

Welcome to the club, we hope you enjoy your time with us.

Clinton Harris has returned after a few years away and will be running in his Datto . We can never have too many Dattos.

We now have 168 members which is more than we have had for a long time. The number of people that are attending Autocrosses is evidence of that, with a good number of the newer members competing. This is all good news for the future of the



club.

Mark Hunter has repaired the seized wheel on the water truck. Thanks Mark that is a job that has been lingering about for quite some time.

The Luxo Barge will be returning soon, i made a quick trip to Cranbourne last Saturday to pick up a manual bellhousing that i have been searching for. I have all the other parts for the conversion, gearbox, clutch, pedals, tailshaft etc, but this was the missing link. So after several months just waiting we should be back on the track in a couple of weeks.

I am going to do infield duty at the Autocross today, the forecast is for rain, i just hope for enough to water the track but not too much.



Anyway, see you at the Club. Regards to all, Wayne.

A reminder for all email recipients of this publication, please keep your email address current with the membership secretary.

Wayne Sanders
Email: w.sanders@optusnet.com.au



Phone:
AH: 5334 2330
Mob: 0412 713023

2011 Hillclimb Calendar

Calendar for 2011

- Round 1 – GCC -29th Jan
- Round 2 - MGCC – 27th Feb
- Round 3 – BLCC Mt Leura – 3rd April
- Round 4 - PIARC 1st May
- Round 5 – Ararat CC One Tree Hill (Clubman or open wheelers excluded) -5th June
- Round 6 – SDCC DECA (to be confirmed) – 3rd July
- Round 7 – VMCI Haunted Hills F8 28th August
- Round 8 – MGCC 18th September

Getting Social

Stay informed join us on FaceBook and Twitter



Ballarat Light Car Club



BallaratLightCC

History **Slice (early correspondence)**



P.O. Box 400
Ballarat,
Victoria,
3353

Ballarat Aerodrome

Ballarat Light Car Club Inc. Leased Area.

Notes:

HISTORY

- The Ballarat Branch of the Light Car Club of Australia (now the BLCC) purchased the current clubrooms at the aerodrome in 1962 from the Dept. of Defence
- In mid 1960s started using area to the east of the "cut-off portion" of the north-south runway, and the runway itself, for motorsport competition
- Permission had been informally arranged between the Shire of Ballarat and the then leasee of the land as the land was not of good quality for grazing or grass growth
- BLCC used this area every 1 - 2 months and earned a sound reputation as a responsible body
- The BLCC has a 47 year history of being a responsible Club and a real member of the Ballarat community. The Club
 - * already conducts driver training and has encouraged a professional driving instructor to set up a business in defensive driving theory and practice,
 - * encourages responsible driver behaviour - starting from as early as 12 years of age,
 - * has been involved in fund raising for the Christmas In July Appeal,
 - * raised far more money than any other local organization to assist our athletes in the last 2 Olympic Games,
 - * worked tirelessly to attract the Dutton's Grand Prix Rallies to Ballarat with the accompanying significant financial boost to local businesses (now apparently lost to this City because of a lack of support from the Council Officers),
 - * organized a meeting in 1994 to sell to Ballarat the financial spin-off possibilities of the Australian Formula 1 Grand Prix in Melbourne
- BLCC approached Shire of Ballarat 1979 about taking over the lease on the whole 84 acre area. Subsequent meetings with the Shire Council at the Shire offices and at the BLCC clubrooms lead to offer from the Shire for a 3 year lease.
- The Shire requested that we also control/sub lease the use of the runway to the newly formed Ballarat Drag Racing Club. The BDRC had also approached the Shire about using some of the land but Council was reluctant for them to have control and they did not wish Shire Officers to become involved. Basically the Shire was very satisfied with our history and standing within the community and was happy for us to take on this responsibility



P.O.Box 400
Ballarat
Victoria

BALLARAT LIGHT CAR CLUB NOMINATION FOR COMMITTEE FORM

I (name) _____ of (address) _____

membership number _____ wish to nominate (name) _____

membership number _____ for a position on the Committee of the Ballarat Light Car Club

Signature _____ Date _____

I (name) _____ of (address) _____

membership number _____ second the above nomination of the member

Signature _____ Date _____

I (name) _____ accept my nomination (signature) _____

This nomination must be received by the Club Secretary no later than July 8th 2011

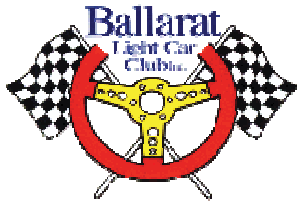

Ballarat Light Car Club

Incorporated (Certificate of Incorporation Number A20023019V)

Application for Membership

P.O.Box 400 Ballarat, Vic, 3353

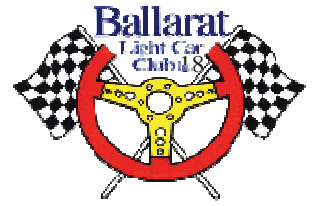

Dear Sir/Madam

I, (Given Names in Full) (Surname)
Mr
Mrs
Miss
Ms

of (Postal Address)

City/Town: Postcode:

Telephones - Private: Business: Mobile:

Email Address: @ DOB:

desire an

ORDINARY / JUNIOR / FAMILY / ASSOCIATE FAMILY / ASSOCIATE PARENT / ASSOCIATE COUPLE
membership of the Ballarat Light Car Club and agree, if elected, to be bound by the rules and bylaws of the club.
(circle the applicable category of membership)

Current Fees (01/07/05)

Category	Nomination	Annual
Ordinary	\$25.00	\$90.00
Family	\$25.00	\$120.00 (2 Parents or Guardians, with any number of own children up to 17y.o or with appropriate dependent student ID)
Associate Family	nil	\$83.00 (2 non-competing Adults, 1 competing child)
Associate Parent	nil	\$58.00 (Parent/Guardian, 1 Child competing)
Associate Couple	nil	\$50.00 (2 non competing adults)

Membership Type: I enclose membership of \$

Occupation / Employer:

Names of Family Members: Partner: Child 1: Child 2:

Child 3: Child 4:

Type of vehicle/s that you will use to compete: Make: Model:

I would like to receive my BULLETIN electronically at my email address above:

Signature: Date:

Please fill in all details and attach appropriate fees when submitting this form

We, the undersigned, being members of the Ballarat Light Car Club, wish to recommend acceptance of the above application of the above application for membership. The above named candidate is personally known to us and we believe him/her to be a suitable person to be elected a member of the Ballarat Light Car Club Inc.

Proposer: Signature: Member No.

Seconder: Signature: Member No.

Areas of Interest

Please tick if relevant boxes

Social

- Clubrooms
- Meetings
- Spectating
- Family Orientated Occasions
- Social Trips

Competition

- Circuit Racing
- Special Stage Rallies
- Trials
- Autocross
- Motokhana
- Hillclimb
- Sprints
- Off Road Racing
- Social Motoring / Touring
- Other (specify)

Officialling

- Rally / Trial controls
- Event Key Official
- Motorkhana
- Autocross
- Scrutiny
- Directing
- Fire/Rescue
- First Aid
- Flag Marshall
- Timing

Office Use Only

Received: / / 20

Fees \$.....

Received

Welcome Letter

Member Number

Completed



If undeliverable return to
Ballarat Light Car Club
PO Box 400
Ballarat Vic 3353

The Bulletin

Print Post Approved

**PRINT
POST**
PP325876/00031

**POSTAGE
PAID
AUSTRALIA**

