



WHAT'S INSIDE:



Noel Peers President report  
PAGE 3



Calendar of Events  
BLCC  
Results :-  
CSA Mt Leura  
Autocross Rnd2  
+ More  
PAGE 6



History Slice.  
PAGE 19

April 2011

# The Bulletin

The Official Publication of the Ballarat Light Car Club

## 2011 Ballarat Festival of Motoring

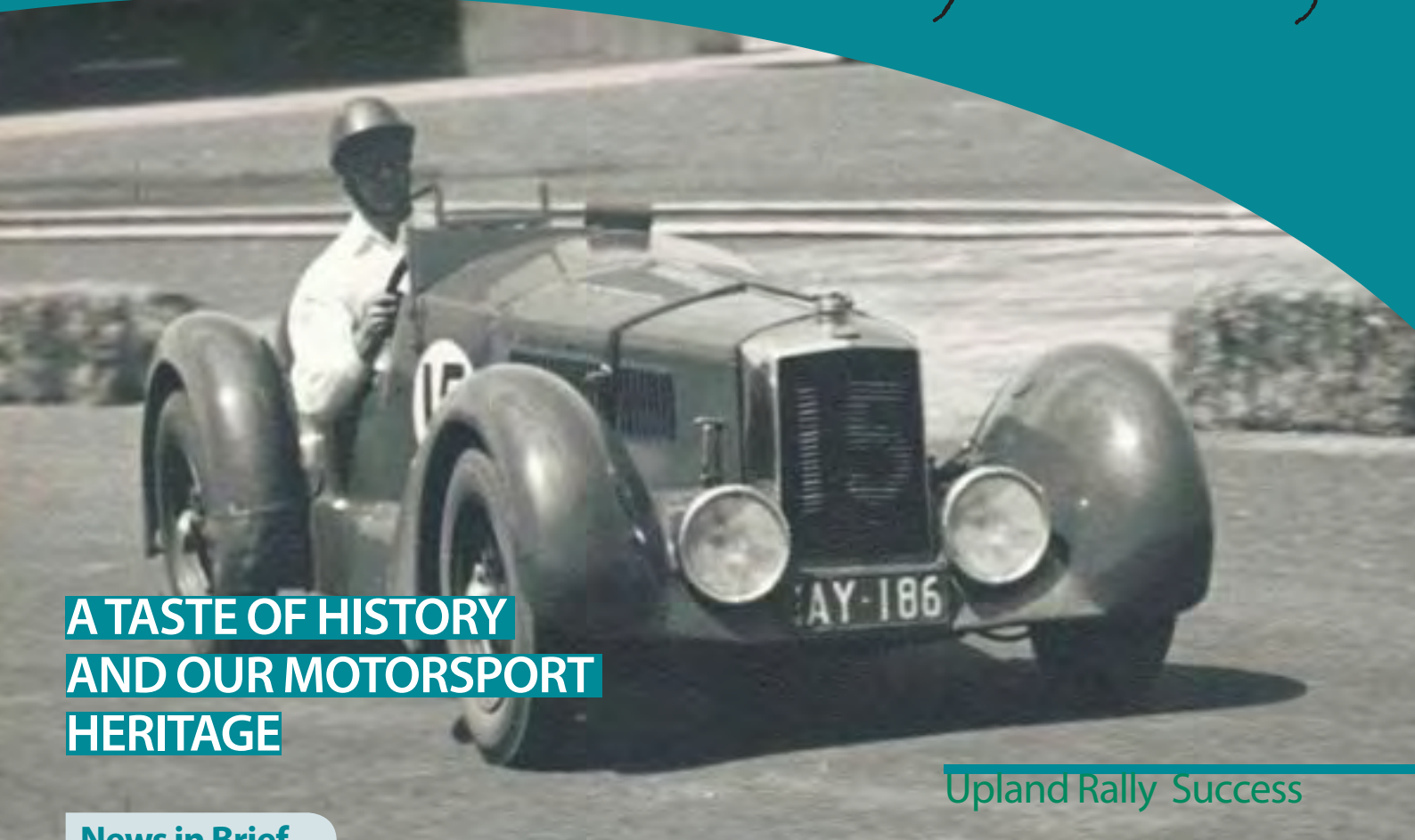

### A TASTE OF HISTORY AND OUR MOTORSPORT HERITAGE

### Upland Rally Success

#### News in Brief

**Upland Stages run and won** Organisers of the Seemore Stages Rally and competitors report that the event was a complete success and enjoyed by all. More Info page 13

**Competition Numbers** On request, the AMRC has recently re-visited their policy on variations to the regulations on Competition Numbers on vehicles. Following discussion, the AMRC confirms their position that the Competition Number

on the vehicle is a "tool" for the better management of racing and not merely a promotional tool for competitors. The regulations prevent the use of triple numbers at national events, and also on the use of numbers starting with zero. Both these uses of numbers has

the potential to create confusion in identification with timekeepers, and also with officials reporting problems or incidents with a particular car and thus are not permitted. For the same reasons, the size and type of numbers used is regulated and must be complied

*Continued page 10*



# Committee 2010 - 11

## The Bulletin

A monthly newsletter of the  
Ballarat Light Car Club

**Editor:** Steve Ezzy

**E-Mail:** blcceditor@hotmail.com

**Mob:** 0400 160 158

**Contribute:** Contributions can be emailed or posted to 1014 Ring Road Ballarat

**Deadline:** 7 pm Thursday, 8 days prior to monthly club meeting.

## Website Info



<http://blcc.net.au/>

**Webmaster:** Wayne Sleep

**AH:** 5339 4890

**Mobile:** 0419 031 712

**E-Mail:** blccwebmaster@hotmail.com

### President

Noel Peers  
**Property Officer**  
AH: 5341 8124  
Mob: 0408 033 895  
blccpresident@hotmail.com



### Secretary

Ange Ruyg  
Mob:  
blccsecretary@hotmail.com



### Treasurer

Clare Bennett  
AH: 5330 2295  
Mob: 0439 652 325  
bennett@ncable.net.au



### Grants Officer

Assistant Media Liaison  
Officer  
Stacey Noonan  
Mob: 0417 163 193  
staceynoonan@hotmail.com



### Events Secretary

**C.A.M.S Liaison**  
**Sport Sub**  
**Committee Chair**  
Rod Hall  
53313546  
0438 313 546  
rod.hall@ballarat.edu.au



### Sports Sub Committe

Ben McGee  
0438 313546 / 5331 3546  
Barney Haddon  
0437 167 790 / 5335 5112  
Damian Faulkner  
0407 643 803

### CAMS

**Sports Club Development Officer**  
Rob Dunt / 9593 7740

**Permits Administrator**  
David Milne / 9593 7732

### Vice President



**State Council Rep**  
Les Noonan  
AH: 5331 6148  
Mob: 0410 524 139

### Membership Secretary

w.sanders@optusnet.com.au  
Wayne Sanders  
AH: 5334 2330  
Mob: 0412 713023



### House Chairman



**M/sport Cplx Manager**  
**Assistant Property Officer**  
**Hillclimb Panel Rep**  
Barney Haddon  
AH: 5335 5112  
Mob: 0437 167 790  
barno4@bigpond.net.au

### CAMS State, AASA

#### Delegate

Ian Brain  
Mob: 0418 518 088  
ibrain@ncable.net.au



### Bulletin Editor



Steve Ezzy  
AH: 5339 4821  
Mob: 0400 160 158  
blcceditor@hotmail.com

*Positions Currently Vacant*

*Rally Panel Representative*

*JDP Co-ordinator*

*Sponsorship*

# Presidents Report April 2011

**G**'day and welcome to the April issue of BLCC's Bulletin.

Well here I am at the last minute trying to put some thoughts down on paper for my report. I guess being on committee does have its privileges, as it is Anzac day and I have a nice big quiet study to sit and ponder in, except for the large fridge in the bar starting up occasionally. I hope your extra long break over Easter and Anzac day has been enjoyable.

That's just it!! it's Anzac Day and the report just doesn't want to appear! 've planned out every day, Anzac Day, up early at 5.15am so as to attend the dawn service at Creswick, that's because mum's family come from out that way and I have 3 uncles on the monument at the RSL with one also being on the cenotaph which I did not know about until the mid 90's. Anzac Day appears to be more significant to me than ever as I have been listening to some

talking books, first Kokoda and I am half way through 'Tobruk' by Peter Fitzsimmons - boy am I learning some history as a lot of this was not taught in school, it should have been though

This last paragraph appeared after going for a walk out the front of the club rooms over the remains of some of the huts. One has big raised blocks, can't work out what that on was but the other was a toilet block with twenty cans!

Thanks to all those involved in the last hill climb at Mt Leura, also those club members who support rallying and officiated at the Uplands Stages in the Wombat Forest. Others that need thanking are those who oved some phone books around (report next month) and all of those involved with Damien Faulkner, Russell McKenzie, Gary Grant and John Emery with our part of the "Ballarat Festival of Motoring". The sprints



took place yesterday on Easter Sunday. Everyone put in a very long day I think even the very shortest would have been in the order of 6 or 7 hours on the job, and the day appears to have been a runaway success, well done everybody!

Coming events, May sees the club running 2 Autocrosses and the Club night, some come along and compete or help out. That will do for now hope to see you soon

Noel Peers  
President

# Treasurers Report April 2011

Once again it is time for the BAS return for the first quarter this year. Our latest fundraiser is the phonebooks which is nearing completion thanks to a huge effort by our President.

The Mt Leura Hillclimb has been run and won. The rough estimate of \$3000 surplus for the Club has been achieved.

The City of Ballarat has given us \$1000 for the assistance provided for the Formula One Grand Prix promotion on Sunday March 20.

Our first term deposit is due now and will be rolled over for the next term.

I have also discussed fees with Bendigo Bank as they were quite high in March. We have been given an extra rebate now. We are charged 70c for each cheque in and out. With direct credit there is no transaction fee so recommend that Club members and others start using this facility more to reduce fee. Bendigo Bank has also contacted me in regard to the Club's interest in using a mobile EFTPOS machine for weekend events and membership renewals etc. I would like feedback re this option.

Our direct credit banking details are as follows;

BSB No: 633-000 Account No: 141857458 You could reduce the paperwork and time spent by the Membership Secretary and Treasurer quite considerably by using this option.

Cheers for now,  
Clare



# New e-Learning for Officials

## CAMS Launches New Look e-Learning for Officials Training

The Confederation of Australian Motor Sport (CAMS) will launch a new look e-Learning program for officials training this month.

The new look system is an update of the online learning which has been available to CAMS officials over the past 5 years. Interactive activities have been developed with the design assistance of the 'Learning Design and Technology Team' at Box Hill TAFE and incorporate the Eworks Learning Management System for record keeping.

New content has been developed with subject matter experts pooled from CAMS officials and members nationally to ensure the currency of training materials. The system has been totally revised to match the instructor-led training CAMS delivers in each state and has now become a fully interactive graphical training tool.

It was recently displayed at the 2011 F1 Qantas Australian Grand Prix to demonstrate its interactive capability and simulations.

Julia Farrell, Training Consultant to CAMS, who has project managed this e-learning upgrade says it provides CAMS officials with a higher level of interactivity than has been previously been available through the use of simulations, videos and user friendly activities that will be of benefit to CAMS officials in their officiating pursuits.



## Proposed **BLCC Book**

In the last 18 months a dedicated group of members have been working on documenting, copying, collating and recording a tremendous amount of material related to the history of our club. They have met regularly with past members and now have the basis for the creation of a valuable historical book covering the 60 years of our clubs existence.

The principle members of this group have now put out the call for people that may be able to contribute to publication by way of volunteering to complete the sorting of this material which is in an electronic form and physical documents, and the publication of the various sections, ie decades and specialist Motorsport areas, people with experience in IT would also be very useful, however any assistance would be gratefully accepted.



# 2011 Apparel Requirements

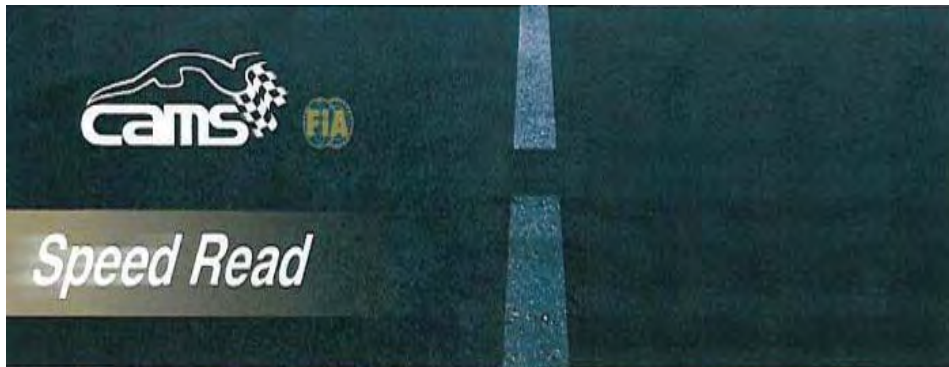

At the end of 2009 there was a significant revision to Schedule D – Apparel, which saw some alterations to the requirements for apparel in various competitions published in the 2010 CAMS Manual of Motor Sport. This followed extensive consultation with the discipline Commissions and also discussion at the 2009 Torquay CAMS Forum which involved motor sport representatives from all levels and disciplines.

Due to the timing of the adoption of the revised Schedule D, a dispensation was provided for competitors to utilise equipment that was valid in 2009 for the duration of 2010, ensuring that there were no immediate updates to apparel required.

Please note that this dispensation is not in place for 2011 and the requirements of Schedule D published in the 2011 CAMS Manual of Motor Sport are now fully applicable. Therefore if you haven't already, it is now appropriate that you examine the requirements for your discipline of motor sport and ensure that your apparel complies with any revised requirements. These can be checked via the following link: [http://www.camsmanual.com.au/pdf/10\\_gen\\_req/GQ05\\_Schedule\\_G\\_Q410.pdf](http://www.camsmanual.com.au/pdf/10_gen_req/GQ05_Schedule_G_Q410.pdf) (3.5MB download) or in the printed version of the Manual.

While in most cases the requirements are not significantly different

to what they were previously, there are some areas where there have been changes. CAMS has received queries in the following areas:

## Circuit Racing

The FIA 8856-2000 and FIA 1986 standard will continue to be the eligible standards for overalls. This does not represent a change.

For gloves and boots however, the FIA 8856-2000 will become the only recognised standard. This is a change from the previous provisions. If your gloves or boots do not carry labelling with this standard clearly shown (they may instead have 'ISO 6940' labelling) then it likely meets the older FIA or other standard and will need to be updated.

## Off Road & Rallying

The overall will need to meet either of the FIA Standards or alternatively the SFI 3.2A/1 (single layer) or superior SFI standard, although this varies in rallying depending on the level of the event. This represents a change with a view to better defining what is eligible. While the majority of competitors will already be using these suits, some may not and therefore this should be checked.

## Helmets

There are no immediate changes other than the introduction of the new Snell SAH2010 and SA2010 standards. However, due to its advancing age, notice is given that the Snell SA95 standard will be phased out from 31 December 2012.

We would strongly suggest you check the labelling of your apparel against the requirements detailed in Schedule D and update where required. If you present with the incorrect apparel it is probable that you will not be permitted to compete until the issue is rectified. This is obviously a situation no one wishes to encounter, so please ensure your equipment is correct.

Finally, while a minimum standard is set out in Schedule D, it is recommended that you consider the underlying safety issues and use those products that will perform most effectively, even if they are not mandated in all cases. For example, in the event of a serious fire the use of underwear to the FIA standard provides useful additional protection due to the additional thermal layer. Similarly the use of a 'Frontal Head Restraint' provides support to the head and neck which can be life saving, particularly in heavy forward impacts. Both measures are recommended by CAMS.



# Event Calendar



## ■ April

### Friday 29th

BLCC Club Meeting

### Saturday 30th

Trailblazer HRA

## ■ May

### Sunday 1st

Central Victorian Autocross Challenge  
round 2 Ballarat (AX3)

CSA Wheels Victorian Hillclimb  
Championship Round 4 PIARC

### Saturday 14th

East Gippsland Stages VRC1

### Sunday 15th

Geelong AX/KX R3 - Autocross

### Saturday 21st

The Italian Connection

### Sunday 22nd

BLCC Autocross Round 4 CDC3

### Friday 27th

BLCC Club Meeting

### Saturday 28th

The Ken Roddnam Memorial Trial

## ■ June

### Saturday 4th

Daryl Tunbridge Trial

### Sunday 5th

BLCC Motorkhana 1 and Khanacross  
Victorian Hillclimb Championship  
Round 5, Ararat

### Sunday 12th

Bega Valley Rally VRC2

### Saturday 18th

Seemore Stages 2,

### Sunday 19th

Winton Sprints CDC4

### Friday 24th

BLCC Club Meeting  
Saturday 25th  
Nissan Nightmoves CTS3, VCRS 2

### Sunday 19th

Geelong AX/KX R4 - khanacross

## ■ July

### Saturday 2nd

Kelly Country Trial, HRA  
BLCC Motorkhana 2 CDC5 and Day  
Night Autocross

### Sunday 3rd

CSA Wheels Victorian Hillclimb  
Championship Round 3 Shepparton.

### Saturday 16th

George Derrick Memorial Rally VRC3 -  
CTS4

Sunday 17th

Geelong AX/KX R5 - Autocross

### Sunday 24th

BLCC, Barney's Double Banger Autocross

### Friday 29th

BLCC Club Meeting

### Saturday 30th

Rich River Revisited, HRA

## ■ August

### Saturday 6th

Baden Powell Introductory Trial Rover  
Scout Motorsport

### Sunday 7th

BLCC, Motorkhana 3

### Saturday 13th

Cooper Memorial Rally Sprint

### Sunday 21st

Geelong AX/KX R6- khanacross

### Friday 26th

Winter Classic Rally and Tour  
No Club Meeting

### Saturday 27th

Winter Classic Rally and Tour  
Ivans Folly

### Sunday 28th

Winter Classic Rally and Tour  
Victorian Hillclimb Championship  
Round 7, Haunted Hills

## ■ September

### Saturday 3rd

Mt Porpunkah Rally Spring  
The Lions Rally

### Saturday 10th

Mafeking Mahem

### Sunday 11th

BLCC, Motorkhana 4 CDC6  
Geelong Motorkhana R1

### Saturday 17th

Marysville Stages, VCRS Round 4, CTS6

### Sunday 18th

CSA Wheels Victorian Hillclimb  
Championship Round 8 Rob Roy  
Geelong AX/KX R7 - Autocross

### Friday 30th

BLCC Club Meeting

## ■ October

### Friday 7th

Bathurst 1000

### Saturday 8th

Wild Dog Stages CTS7  
Bathurst 1000

### Sunday 9th

Bathurst 1000

Proposed BBQ and Bathurst day at  
BLCC Clubrooms. (register your interest  
bathurst2011@blcc.net.au)

### Saturday 15th

Akademos VRC4

### Sunday 16th

Sandown Sprint CDC8  
Geelong AX/KX R8 - khanacross

### Friday 25th

BLCC Club Meeting

### Saturday 29th

Bagshot Rallysprint

## ■ November

### Saturday 5th

Coghlan's Carnival

### Friday 6th

Coghlan's Carnival  
Geelong Motorkhana R2

### Saturday 12th

Rally Victoria

### Sunday 20th

Reserve Date for BLCC Autocross and  
Series  
Geelong AX/KX R9 - Autocross

### Friday 25th

BLCC Club Meeting

### Saturday 26th

Alpine Rally

## ■ December

### Saturday 3rd

Ararat One Tree Hillclimb

### Sunday 4th

Ararat One Tree Hillclimb

### Sunday 11th

Geordie Fawcett Memorial Autocross,  
Xmas Breakup  
Geelong Come & try khanacross

**Notice to Bulletin Advertisers**

If you wish to place an advertisement, please consult the Treasurer, **Clair Bennett** (5330 2295 or 0439 652 325) who will arrange an invoice and pass the request to the Editor, **Steve Ezzy**, for inclusion in the appropriate issues.

Please see the table below for the Annual Fee for Advertising

Size	Annual Fee (\$)	1 Month Fee (\$)
Full Page	220	22
Half Page	143	14.30
Third Page	119	11.90
Quarter page	99	9.90
Sixth Page	89	8.90
Eighth page	79	7.90

Member Small adverts of the Buy, swap & Sell type will continue to be **Free**

# Club Scrutineers

Chris Hall	Grade 2	5342 4397 0438 094 684
Noel Peers	Grade 3	5341 8124
Darren Wythe	Grade 3	0448 417 506
Ben McKee	Grade 3	5336 1172 0418 313 695
Wayne Webb	Grade 3	5334 7698

## Your Club Get Involved

### Editorial

#### Doing it for the club

There are often tasks that need completing or some work that needs to be done around the club. More often however we are a time poor lot and there are many other things going on (many hands make light work).

This does not have to mean that there is nothing that you can do for the club. Many of us have skills that are useful and can be easily utilised. Computer or IT skills, communications, design, carpentry, driver training fund-raising you name it there is always at some time or another something useful that you can do that does not involve actually doing car stuff. So if you can only cook one barby in a year or do up a page for the Bulletin, service a JDP car or deliver phone books we will value your contribution.

Have you ever sat in a room full of people and still felt like your own? No, well how about being in a club and feeling the same way, at the risk of getting too philosophical or negative let me tell you about the genuine Bulletin writing experience.

In recent and not so recent times some of our co-members have taken it upon themselves to express their opinions about this simple publication. Between myself and co-editor Wayne we necessarily put quite a bit of time aside to try and ensure that it is of the highest standard.

We have a responsibility to our members to gather and publish all things that we imagine will be of greatest use to them and we try to be more than just a method of delivering a calendar and results. There are many who appreciate what we do but like all negatives, one comment or complaint washes away many positives.

I would expect that these words will possibly never affect these folks as they possibly never read them anyhow. However if they would like to make comment I would like to publish their thoughts so future improvements can be made.

All comments will be published as will any contributions so whether you have a car for sale or a tomato that grew in the shape of a duck even a picture of interest to other members, like your missus polishing the rally car or a really nice place you think other members would appreciate then email it, mail it or deliver it.

Alternatively if there is something that you would like me to organise, an idea for an event or something you would like to know about, please let me know.

I was out at the Festival of Motoring on Easter Sunday and I would have to say that all present were delighted by the content, its administration and the crowds. The professional attitude and aptitude exhibited by our members was second to none and made me feel proud to be a member of BLCC



# autoparts

PROFESSIONALS  
BALLARAT

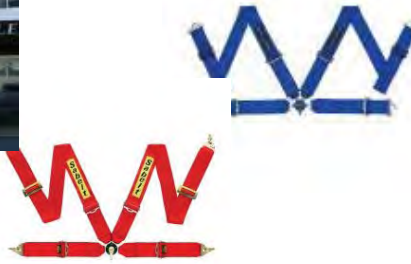

- 3" RPM Harness FIA Approved 4PT **Red, Silver, Black, Blue** \$249
- 3" RPM Harness FIA Approved 6PT **Red, Silver, Black, Blue** \$269
- 2" RPM Harness AS2596 4PT **Red, Black, Blue** \$195



Willans Harnesses also now available in **Silver, Red, Blue and Black** \$399



SaBelt 4pt Harness, **Red**, \$445



**Sparco PRO ADV Raceseat, \$1395 IN STOCK!**

**Spacro EVO Raceseat \$1099 IN STOCK!**

**Cobra Monaco Raceseat FIA \$495 IN STOCK!**

**KIRKEY Alloy seats from \$269 IN STOCK!**

**JAZ/RPM Plastic Seats from \$119 IN STOCK!**



**RPM Helmets, Best seller for 2009!**

RPM Rally Open Face \$399

RPM REV-1 Full Face \$499

RPM PUMPED Force Air \$699

All SA 2005 Approved, Lightweight Composite Shell, Kevlar Strap and Nomex lining, Great value, HANS Ready, all in stock!

BELL Helmets also stocked starting from \$799

HANS Device from \$950 in stock!



RPM Clubsport Single Layer Suit \$299

RPM Club Gloves \$89

RPM Mondial Double Layer FIA Suit \$699

Packages starting from \$849

Mechanics Gloves from \$29.95

**Call in and see Nathan and David, for there huge range of stock, 7 days a week, for friendly advise and great prices, supporting the Ballarat light car club for 15 years!**

**Auto Parts Professionals, 9 Doveton St Nth, Ballarat, 53329333**

# *Festival of* **Motoring 2011**

Over the Easter break a series of events were held in Ballarat to commemorate the anniversary of the 1961 Formula 1 Victoria Trophy Race. It was fitting that the Ballarat Light Car Club, who in conjunction with its parent club Light Car Club of Australia, ran the '61 event at our airfield. As in the past, an enormous amount of planning, organisation and the help of many volunteers was required. President Noel, his committee and members supported, helped plan and professionally ran the motorsport event on Easter Sunday, with many accolades from competitors and spectators. Event organisers John Emery and Gary Grant hope to visit a club meeting soon.



## News in Brief *continued*

with. However, provided that the numbers are clear and easily identified, variation to the standard sizes is permitted for specific categories on application. The AMRC noted that there is ample scope on the rest of a vehicle to feature numbers integral to promotional and sponsorship needs.

### Club Historian

The committee is calling for expressions of interest from persons interested in becoming the club historian.

### Log Books

All competing cars must present with either a "Club" log book or one issued by CAMS.

### Good News

CAMS now permit you to use FAI approved seat belts with "valid to" dates for a further 5 years. For example "Valid To December 2008" can be used up to December 2013.

### Club Points Compiler

We are **still** searching for someone to take on the role of Club Points Compiler. If you are interested in filling this position please contact a committee member. Please note if someone does not step up to fill this position the CDC etc will go un-scored this means no trophies.

### Western Link Road

The Ballarat Western Link Road would connect the Western Highway near the Ballarat Airport and the Midland Highway to the south of Sebastopol. It would serve new developments at the Airport precinct and residential developments in Ballarat West and would be approximately 16 kilometres long. Recent studies have identified a preferred alignment that is two lanes wide in each direction from Glenelg Highway to the Western Highway in the north, and one lane wide in each direction from Glenelg Highway to Midland Highway in the south. However, transport modelling has shown that the ultimate road configuration as described above would not be required until 2031.

# ROBSON GLASS

Established over 98 years

Shop Fronts



Broken Glass Replacement



24hr Emergency Service



Cut To Size Glass & Glazing



Insurance Work



Lead Lighting



Mirrors



Safety & Sound Proof Glass



Glass Splashbacks



Shower Screens



Double Glazing



W J ROBSON & SONS PTY LTD  
**5332 2078 MBL 0418 508 429**

After Hours 5341 3898 or 5339 4664  
Cnr Maun Rd & Humffray St Ballarat



**Liability Disclaimer** – All material in this magazine represents the opinions of the authors and does not carry any endorsement by the Editor or the Committee, Ballarat Light Car Club has no official connection with any public or commercial organisation and it does not provide product recommendations. Names of commercial products mentioned in this magazine are registered names and trademarks of their owners. Copyright Notice – Material in this magazine may be copied by any other club without fee or written permission provided that the copyright rests with the Ballarat Light Car Club. The copies are not to be used for commercial advantage and the origins of the material and this permission to copy are acknowledged in the reprinted item. The Nissan Car Club-Australia is acknowledged as the source for the wording of this Disclaimer.

# CSA Alloy Wheels Mt Leura Hill Climb

Well folks the hillclimb has come and gone. If you didn't compete in or assist with the running of this event or come for a look then you missed out. The Good Lord was much kinder with the weather he provided this year although the looming clouds kept the other Mr Hall (Chris Hall) very nervous.

The results should be elsewhere in your Bulletin. There were a few notable successes to our BLCC contingent. The following people all won their classes : Glenn Latter, Steve Grinstead and Chris Hall. Sharon Pitt won the Fastest Lady trophy.

These events don't happen without the efforts of a few diligent few and lots of helpers. The main organisers were Barney Haddon and Clare Bennett along with yours truly. Next time you see them give em a pat on the back and say thanks. Thanks from yours truly as well guys as the event wouldn't have happened without you. There is also a large contingent that tow trailers, sit on corners, man the return grid, book competitors in, supply and drive



recovery vehicles (thanks Mick), drag tyre barriers, run cables, scrutinise cars etc, line up cars before the start and on the start line, time the cars, cook breaky for the helpers on Sunday morning. Big thanks to the following who carried out these duties, please again give em a pat on the back : Paul Duncalf and his mate, Ben Ezzy and his mate Anthony Muscat, Damian Faulkner, Rob Prosser, Steve Ezzy, Wayne Sanders, Wayne Sleep, Mark Bennett, Noel Peers, Dave Marmo, Mick Goossens, Peter Marmo, Dave Jowett & Son, Paul Gladman, John Welford, Dave Stewart, Mark Hunter, Leslie Smart and Les D the chief scrutee. Glenn Latter also had a hand in helping by dragging our recovery trailer down which sadly was needed when a little clubman had a mishap in the cutting.

We also owe the Camperdown Council a vote of thanks for a significant resurfacing of the track. There was lots of grip off the line as many of the competitors remarked. There weren't as many burnouts this time although the man in the black rotary powered Mazda once again entertained us whilst he warmed the tyres up. Others just warmed up the clutch apparently. Scott Ball one of the locals at Camperdown has been doing some great promo work and getting a few jobs done locally for us. Thanks Scotty as its always handy to have someone on the ground helping out.

Award for the most inappropriate car went to some goose who thought he was off to Bell's Beach in his Mini Moke and had surf boards bolted to the roll cage just for image.

## AX Series 2011 Rd 2 CDC1

### Outright Results

06/03/2011



No	Name	Car	Class	Prac	Hats	Run 1	Hats	Run 2	Hats	Run 3	Hats	Run 4	Hats	Total	OR	Class
19	John Austin	Lancer EVO2	F	80.671	0	79.594	0	81.141	0	79.325	0	80.323	0	158.919	1	1
23	Ben McKee	Subaru Liberty	F	83.42	0	81.439	1	81.737	0	81.419	0	80.323	0	161.742	2	2
26	Ash Findlay	Subaru WRX STI	F	85.324	0	83.398	0	81.106	0	81.386	0	80.969	1	162.492	3	3
25	Keith McElroy	Subaru WRX STI	F	84.854	0	82.954	0	84.9	0	82.312	0	83.116	0	165.266	4	4
31	Steve Smith	Buggy	I	88.206	0	84.763	0	84.303	0	82.735	0	84.174	3	167.038	5	1
1	Stefan Dekker	Toyota MR2	A	85.916	0	87.681	0	106.089	0	84.54	0	83.913	0	168.453	6	1
17	Daniel Hall	Pulsar ET	I	88.288	0	86.223	0	90.731	0	86.466	1	84.919	0	171.142	7	2
30	Chris Hall	Pulsar ET	I	89.073	1	87.158	0	86.405	0	85.801	0	85.49	0	171.291	8	3
6	Robert Schenk	Laser	B	88.343	0	89.18	0	87.189	0	86.04	0	85.438	0	171.478	9	1
22	Les Noonan	Mazda 323	F	86.871	0	85.858	0	86.129	0	85.93	0	86.494	0	171.788	10	5
29	Leon Pegg	Gemini	H	112.417	0	87.254	0	85.214	0	87.991	0	86.803	0	172.017	11	1
39	Les Liston	Peugeot	D	94.952	0	91.433	0	86.668	0	93.599	1	85.363	0	172.031	12	1
10	Ben Davis	Corolla	C	89.136	0	87.61	0	88.453	1	87.366	0	85.039	0	172.405	13	1
21	Arron Secombe	Mazda Familia	F	86.275	0	87.669	0	86.881	0	121.822	0	86.305	0	173.186	14	6
13	Ian Brain	Peugeot	D	90.735	1	87.985	0	89.382	2	85.972	1	85.368	0	173.353	15	2
18	Gareth Clark	Buggy	I	90.704	0	87.464	0	88.689	0	86.218	0	88.443	1	173.682	16	4
24	Keith Scott	Subaru WRX	F	91.483	0	86.922	0	88.604	0	87.174	0	86.218	1	174.096	17	7
33	Craig Hunter	Bluebird	J2	91.546	0	88.661	0	87.681	0	88.139	0	87.157	0	174.838	18	1
20	Les Baxter	Magna AWD	F	90.602	0	90.341	0	90.274	0	88.303	0	86.61	0	174.913	19	8
8	Evan Dekker	Toyota MR2	A	86.047	0	89.773	0	87.981	1	88.817	0	86.476	0	175.293	20	2
2	Paul Gladman	Pulsar	A	89.234	1	90.572	0	89.309	0	86.355	0	86.187	1	175.664	21	3
11	Greg Pitt	Honda CRX	C	90.877	0	89.123	0	90.915	1	88.306	0	87.639	0	175.945	22	2
9	David Jowett	Pulsar	A	91.88	0	89.79	0	88.468	0	87.903	2	88.105	0	176.573	23	4
14	Ross Stapleton	Nissan 200SX	D	92.88	0	88.617	0	94.502	0	92.983	0	88.04	0	176.657	24	3
38	Scott Hunter	Bluebird	J3	92.087	0	88.706	0	99.452	2	88.023	0	89.562	0	176.729	25	1

# AX Series 2011 Rd 2 CDC1

## Outright Results

06/03/2011



No	Name	Car	Class	Prac	Hats	Run 1	Hats	Run 2	Hats	Run 3	Hats	Run 4	Hats	Total	OR	Class
4	David Marmo	Falcon	B	88.848	0	90.447	0	90.46	0	90.110	0	88.714	0	178.824	26	2
3	Robert Dekker	Laser	A	89.693	0	91.206	0	106.867	0	88.784	1	88.729	0	179.935	27	5
28	Robert Prosser	Celica	H	93.08	0	91.729	0	89.747	0	91.333	0	109.812	1	181.08	28	2
36	Sharon Pitt	Honda CRX	L	99.106	0	97.358	0	94.621	0	91.79	0	91.413	0	183.203	29	1
12	Henk Dekker	Toyota Sprinter	C	93.614	0	94.69	0	93.807	0	96.834	0	90.205	0	184.012	30	3
16	John Welford	Peugeot 504	D	96.981	0	93.846	0	96.077	0	92.275	0	93.093	0	185.368	31	4
37	Kate Meyer	Nissan Bluebird	L	102.356	0	97.246	0	93.523	0	93.085	0	92.792	0	185.877	32	2
15	Peter Stapleton	Datsun 200B	D	95.485	0	94.671	0	98.223	0	91.752	0	92.795	1	186.423	33	5
27	Marc Salter	Corolla	H	100.748	0	98.41	0	92.99	0	96.261	0	93.866	0	186.856	34	3
5	Matthew Davies	Escort	B	99.269	0	97.816	0	97.881	1	95.525	0	95.063	0	190.588	35	3
35	Bronwyn Salter	Corolla	L	106.949	0	106.922	0	101.759	0	102.644	0	99.964	0	201.723	36	3
7	Michael Brooks	Alfa	A	107.417	0	106.101	0	105.62	0	116.822	0	106.491	0	211.721	37	6

# AX Series 2011 Rd 2 CDC1

## Classes Results 06/03/2011



No	Name	Car	Class	Prac	Hats	Run1	Hat	Run2	Hat	Run3	Hat	Run4	Hat	Total	OR	Class
<i>Standard up to 1800cc</i>			<b>A</b>													
1	Stefan Dekker	Toyota MR2	A	85.916	0	87.681	0	106.089	0	84.54	0	83.913	0	168.453	6	1
8	Evan Dekker	Toyota MR2	A	86.047	0	89.773	0	87.981	1	88.817	0	86.476	0	175.293	20	2
2	Paul Gladman	Pulsar	A	89.234	1	90.572	0	89.309	0	86.355	0	86.187	1	175.664	21	3
9	David Jowett	Pulsar	A	91.880	0	89.79	0	88.468	0	87.903	2	88.105	0	176.573	23	4
3	Robert Dekker	Laser	A	89.693	0	91.206	0	106.867	0	88.784	1	88.729	0	179.935	27	5
7	Michael Brooks	Alfa	A	107.417	0	106.101	0	105.62	0	116.822	0	106.491	0	211.721	37	6
<i>Standard over 1800cc</i>			<b>B</b>													
6	Robert Schenk	Laser	B	88.343	0	89.18	0	87.189	0	86.04	0	85.438	0	171.478	9	1
4	David Marmo	Falcon	B	88.848	0	90.447	0	90.46	0	90.110	0	88.714	0	178.824	26	2
5	Matthew Davies	Escort	B	99.269	0	97.816	0	97.881	1	95.525	0	95.063	0	190.588	35	3
<i>Modified up to 1800cc</i>			<b>C</b>													
10	Ben Davis	Corolla	C	89.136	0	87.61	0	88.453	1	87.366	0	85.039	0	172.405	13	1
11	Greg Pitt	Honda CRX	C	90.877	0	89.123	0	90.915	1	88.306	0	87.639	0	175.945	22	2
12	Henk Dekker	Toyota Sprinter	C	93.614	0	94.69	0	93.807	0	96.834	0	90.205	0	184.012	30	3
<i>Modified over 1800cc</i>			<b>D</b>													
39	Les Liston	Peugeot	D	94.952	0	91.433	0	86.668	0	93.599	1	85.363	0	172.031	12	1
13	Ian Brain	Peugeot	D	90.735	1	87.985	0	89.382	2	85.972	1	85.368	0	173.353	15	2
14	Ross Stapleton	Nissan 200SX	D	92.880	0	88.617	0	94.502	0	92.983	0	88.04	0	176.657	24	3
16	John Welford	Peugeot 504	D	96.981	0	93.846	0	96.077	0	92.275	0	93.093	0	185.368	31	4
15	Peter Stapleton	Datsun 200B	D	95.485	0	94.671	0	98.223	0	91.752	0	92.795	1	186.423	33	5



## E-mail Notifications.

**A** new e-mail notification system has been implemented on our site to simplify the process of keeping members and other interested parties informed of goings on in the club.

Sign up to receive event updates and announcements from Ballarat Light Car Club about upcoming events and activities. E-mail announcements will be sent out occasionally about website-related activities and new website features.

Note: this feature is not in place of the electronic send out of the club newsletter. And all recipients of the bulletin should feel free to sign up for notifications.



## Proposed Members Business Register

I was pondering how I was going to find someone to complete the removal of a huge amount of Wisteria from my side fence. I considered the phone book for a moment and as I did so I thought about who in the BLCC might know someone from the club who knew someone? I was then prompted to think about the amount of useful information that could be collated into a list of useful business / skills / hobbies that people have, do or run.

To this end I thought I might put my idea out there, I will collect a list of members (proposed to me) of people who are likely to be useful to other members. I do not propose that there be any discounts or freebies just a list of people and their field of expertise.

So, if you make stickers, weld up roll cages, are an expert in suspension, electronics, gardening, office supplies, sell bolts, make trailers, are a retired business man willing to offer advice, are an expert in IT or lay cement than you should be on this list.

If you would like to be on this list (Name, Number and field) then SMS or Phone me Steve Ezzy 0400 160 158 or email blcceditor@hotmail.com

**M**embers listed below have nominated themselves as being willing to assist fellow members

**Ian Brain** (expert in restorations and pressed metal ceilings)

- 0418 518 088 or 5332 2828

**Peter Ellis** (Driving Ambition) Driver Training Specialist to Individuals and Business - Mobile 0419 002 007 Tel. (03) 5334 3144



# Mechanica Industries

design · create · repair · salvage

- Mechanical engineering
- Automotive maintenance & repairs
- Machine shop
- On-site maintenance

*If its metal, we can design it, create it, repair it or salvage it.  
At Mechanica Industries, we love machines!*

Mechanica Industries are located at **12 Paddys Drive Delacombe 3356**

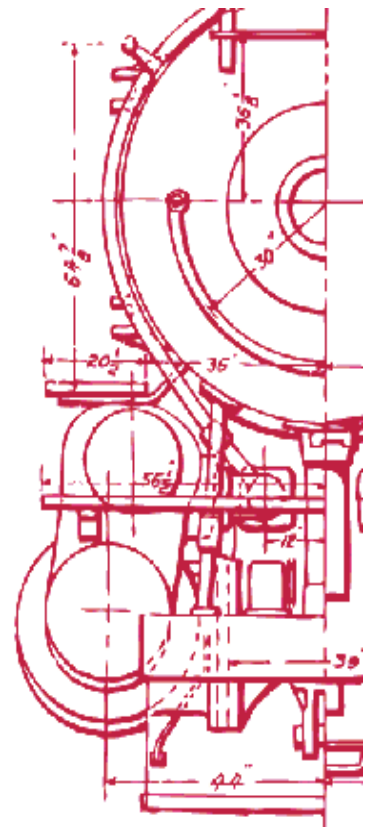

[www.mechanicaindustries.com.au](http://www.mechanicaindustries.com.au)

# 5335 7251

# Sport Sub Committee Notes

Sports Sub Notes April 2011

Come and Try Day was very well patronised and some good publicity was gained. New members are being followed up. The following Autocross started a bit late because of the number turning up for the training part. The Autocross was well patronised as well with over 50 entries. Thanks to **Ian Brain** and **those of us** who responded by helping on the day

Millard Trial has been run and won but not by any-one from BLCC. Reminiscent of the old Robson Cup style of events. If considering doing this event next year make sure you have a navigator who can read maps and plot a course as there is some of that in this event which is an annual event. **Steve Richards** who had a competent navigator who could read maps in **Fred Lakerink** was going well until the Escort Starter motor developed an ulcer or arching blowhole

The BLCC annual Trophy night was a good night enjoyed by all and sundry. Most of the trophies for last years competition were able to be handed out except for a couple of apologies (some of who kindly kept us updated of their exploits in a Rally in the "apple isle" via SMS on the night). Big thank-you to Keith McElroy as our guest speaker who kept us enthralled with his exploits making the trip to Cape York in a Renault.



AX Round 2 Directed by **Chris Hall** and **Rod Hall** with **Noel Peers** helping when he could. 38 entries rolled up. Thanks to **Greg Pitt** who graded the track for us. Thanks to **Mark Hunter** who borrowed on our behalf a **BIG** water truck which held some 16K litres which it could put out real quick. **Mark Hunter** and **Mark Salter** have kindly offered to set up the BLCC with a similar setup to get the water out quick although I'm not sure they can increase the capacity to 16000 litres from 4000, but ya never know.

The Uplands Stages that was on the 19<sup>th</sup> March had to be postponed till the 16<sup>th</sup> April because the DSE were doing controlled burns in the forest. The new date is to remain the same event from the original date. It will also remain part of our BLCC Club Trials Championship. By the time you read this it will have been run and won.

Round 3 Autocross on 1<sup>st</sup> May will now be just a round of our BLCC series. The CVAC designation wont happen as the other clubs still haven't come to a meeting. A few of us here have been a bit busy too. It will

however have a new initiative trialled during the scrutiny time. **Mark Hunter** has kindly offered to run a motorkhana during the scrutiny time for juniors in the 12-14 age group or older if they are inexperienced. This is **Mark's** initiative which is a great idea to give those that are too young for Autocrosses something to do. In most cases they will be at the AX with Mum and/or Dads car already entered in the AX. There is a separate entry form for this activity. There is a minimal cost of \$5 (which buys a burger somewhere ??). If you want to take part in this please turn up early so we can get the vehicle scrutinised and send you on your way to leaning some skills so you are ready to do Autocrosses when you are old enough. Entries for this event will be accepted at the clubnight this Friday night. The regs haven't come back from CAMS as I write this but should be here any tick of the clock. Easter sort of got in the way as we all have holidays and it seems so do CAMS.

The CDC Sprint Round at Sandown is now confirmed on the 16<sup>th</sup> October. Previously it was a tentative date but the Maserati Club have now confirmed the date. The Winter Track Day at Winton is on the 16<sup>th</sup> June.

MK and KX on the 5<sup>th</sup> June will happen in that order to allow progression of learners and juniors and allow us old stagers to get our eye in perhaps. Have a director for the MK just need a team for the KX (or vice versa).

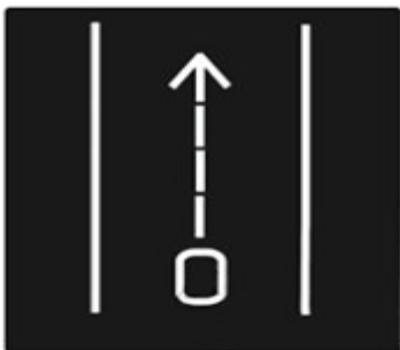

**FAST CAR**



**FAST DRIVER**



## CTC Series Competitors: Early Entry

This year, the general lack of rallies is causing events to fill up fast. To make sure you get a run, you will need to enter quickly when entries open.

The Sport Sub Committee has decided not to remove events from the CTC Series if someone misses out, unless they have entered within 10 days of entries opening for that event and been refused

**House & Home**

- House Renovations & repairs
- Plasterboard Hanging & Finishing
- Floor & Wall Tiling
- Concreting. Shed slabs, path's, driveways
- Tree felling & lopping
- Any size job
- Quality work
- Upholstery coming soon!

**Signs & Graphics**

- Race & Rally Signage
- Magnetic Signs
- Boards, Banners & A Frames
- Shop front & Business signage

**Vehicles**

- Competition car preparation, Panel beating & Spray painting
- Welded Rollcages to Cams specs
- General welding (Cert. 8G) & fabrication.

**Wayne & Angela Webb**  
 10 Frawleys Rd, Leigh Creek, 3352  
 PH: 53 347698 OR MOB: 0438 347 698  
 Email: [webballtrades@westnet.com.au](mailto:webballtrades@westnet.com.au)

## Sport Sub Committee

Rod Hall (Chair) Barney Haddon, Ben McKee, Darren Wythe (Rally Liason), Damian Faulkner, Steven Richards, Wayne Sleep, David Marmo, Peter Marmo, Ben Divis.

Meetings: Wednesday night immediately prior to monthly committee meeting.

## Leaving the complex after Scrutineering

If a competition vehicle needs to leave the motor sport complex, you must remove your numbers so the Police or Vic Roads don't nab you. Also the vehicle needs to be re-presented for scrutiny upon its return before continuing competition.

## CH and H Plated Cars

From December 1st 20?? A small fee of \$5 will be charged for new and renewal registrations. Chris Hall will collect this when he signs your form. Special use vouchers will also cost \$5. These vouchers must be used when you drive your car for any purpose other

than a BLCC calendared event. The BLCC recently became a member of the Association of Motoring Clubs. The AOMC is working closely with Vicroads on the scheme to introduce a 90 day log book (with a 54 day option). In order to have an input and to be kept informed of the latest

news we needed to join this club. To cover the costs of this membership and the vouchers it has been necessary to impose this small fee. If you have any questions please contact Chris on 5342 4397 or 0438 094 684.

Club Driving Instructors					
John	Bourke	Wayne	Drew	Rod	Hall
Richard	Gay	Gary	Harrowfield	Barney	Haddon
Mick	Goossens	Engels	Leoncini	Peter	Ellis
Les	Liston	Simon	Ellis	Darren	Wythe
Darren	Everett	Ben	McKee	Steve	Richards
Damian	Faulkner	Russell	McKenzie	Mark	Fawcett
Ben	Fawcett	Steve	Wilson	Chris	Hall
Keith	McKelroy	Ben	Davis		

# Membership



## WELCOME NEW MEMBERS

This month we welcome to the Club.

James Scott, who joined at the last club meeting. James has a BMW 318i that he is prepping for the next autocross.

Peter Jowett. Son of Dave. Peter turned 12 on the day of last club night so he sent Dad to the meeting to join him up. Now that is a keen junior!

Tim Patterson who drives a Nissan Cefiro  
Allan Cattermole, with a Chrysler Galant.

Tim and Allan were both introduced by Dave Darwin and from what i here are both quite keen on performance cars.

The Members welcome you to the Club and hope you enjoy your time with us.

Well The last Month has fairly busy with a Hill Climb, a Rally and the Festival of Motoring.

I went to Mt Leura on Saturday to help with set up and practice, the weather was mild and sunny for a change. My only complaint is that the trees have grown so tall that i can't see the start line from the finish

any more. Leon Pegg smoked the clutch in Charlies Commodore during practice but i heard they were back and running on Sunday after some quick spanner work overnight. Good work lads.

On the 16th there was a round of the Two Wheel drive Masters rally series in the Wombat Forest. There was a good turnout of members either competing or officialing. Some different cars were competing that i havn't seen before including a 6 Cyl BMW from Bega, a Mazda RX8, a Turbo RWD Toyota Celica and a Hyundai Getz straight from the showroom. I could smell that new car smell when they opened the door to give me their time card at the finish control, not the usual burning brakes and hot oil. But there is still nothing quite like 3 Commodore V8s!

From where i was standing, at the start line, the "Festival of Motoring" was a success with bucket loads of history in both the cars and drivers. There were old drivers in old cars who wern't afraid to have a fast



run, but the car that appealed to me the most was a genuine Lancia Stratos. How they could drive such a small car so fast in the forest amazes me. Thats why they got paid the big money i guess. Anyway, see you at the Club. Regards to all, Wayne.

**A** reminder for all email recipients of this publication, please keep your email address current with the membership secretary.

Wayne Sanders  
Email: w.sanders@optusnet.com.au



Phone:  
AH: 5334 2330  
Mob: 0412 713023

## 2011 Hillclimb Calendar

**C**alendar for 2011

- Round 1 – GCC -29th Jan
- Round 2 - MGCC – 27th Feb
- Round 3 – BLCC Mt Leura – 3rd April
- Round 4 - PIARC 1st May
- Round 5 – Ararat CC One Tree Hill ( Clubman or open wheelers excluded) -5th June
- Round 6 – SDCC DECA (to be confirmed) – 3rd July
- Round 7 – VMCI Haunted Hills F8 28th August
- Round 8 – MGCC 18th September

## Getting Social

Stay informed join us on FaceBook and Twitter



Ballarat Light Car Club



BallaratLightCC

# History Slice

## Celebrity Challenge

Olympians, councilors, politicians and media representatives were heavy on the accelerator, and in some cases the brake, on Saturday when they competed in the Ballarat Light Car Club's celebrity challenge.

The challenge raised \$2700 for the Central Highlands Olympic Fundraising Committee.

Each team member had to drive a car manouverability test which involved weaving in and out of a series of witches' hats in the quickest possible time.

Twelve teams competed with 3BA winning in 57.06 seconds.

3BBB was second in 57.78 seconds and Prime TV third in 58.06 seconds.

Fastest driver was Peter Ellis driving for 3BBB with a time of 28.09 seconds.



The best presented team was Shannon Stevenson and Brendan Caligari from The Courier.

The event's organizer Trevor Ryan, of the Ballarat Light Car Club, said he was disappointed as few spectators turned up to watch probably because there were so many other things

happening in Ballarat this weekend.

He thanked the sponsors and other Ballarat businesses for making the day a fundraising success.

Those taking in the challenge did not seem to mind the lack of spectators; they all said they had had a marvelous time and would like to try it again.

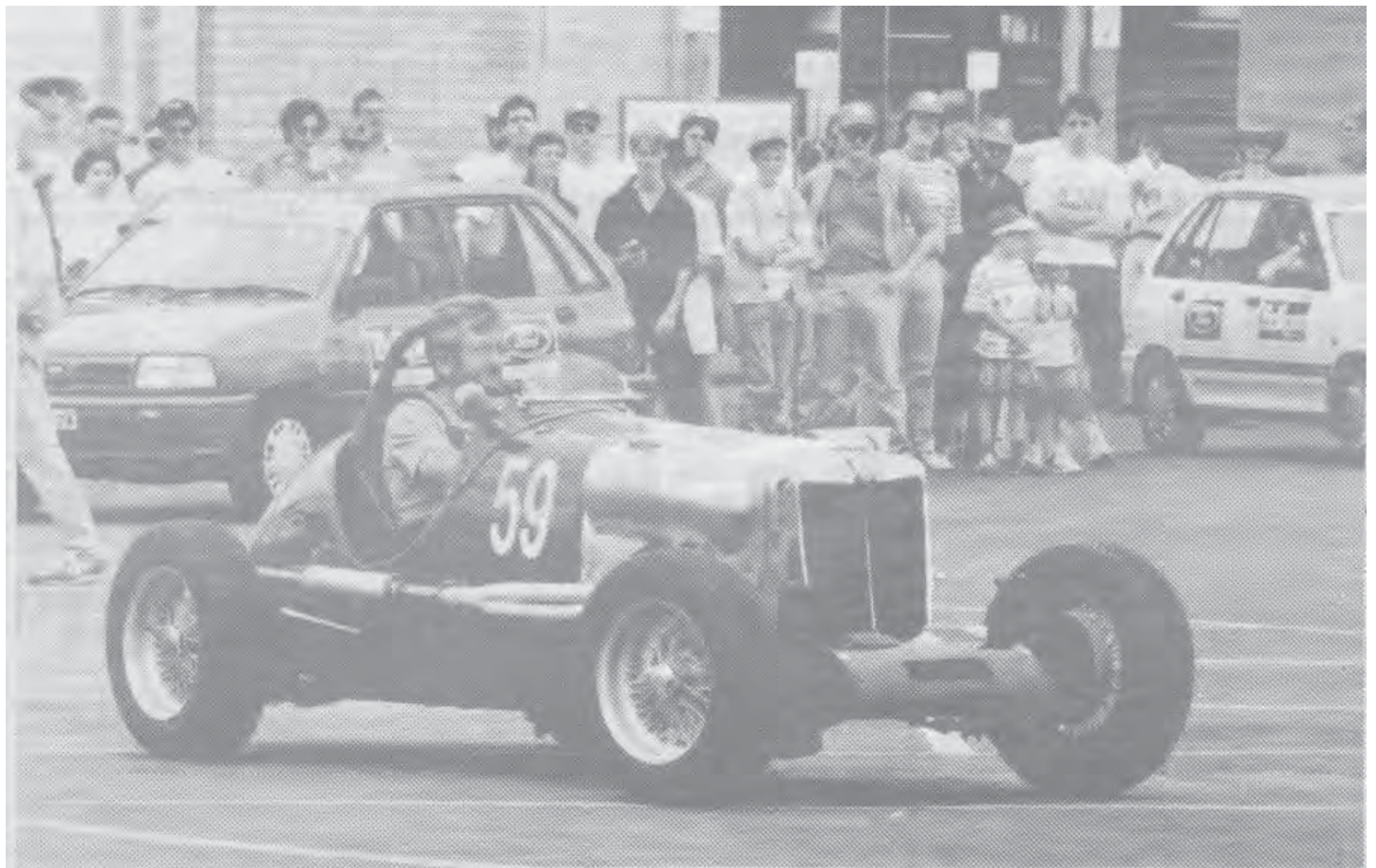





# Ballarat Light Car Club

Incorporated (Certificate of Incorporation Number A20023019V)

## Application for Membership

P.O.Box 400 Ballarat, Vic, 3353

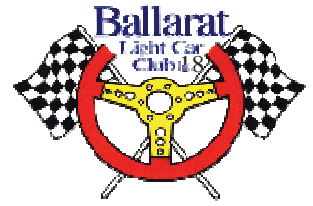

Dear Sir/Madam

I,  Mr  Mrs  Miss  Ms \_\_\_\_\_  
(Given Names in Full) (Surname)

of \_\_\_\_\_  
(Postal Address)

City/Town: \_\_\_\_\_ Postcode: \_\_\_\_\_

Telephones - Private: \_\_\_\_\_ Business: \_\_\_\_\_ Mobile: \_\_\_\_\_

Email Address: \_\_\_\_\_ @ \_\_\_\_\_ DOB: \_\_\_\_\_

desire an

**ORDINARY / JUNIOR / FAMILY / ASSOCIATE FAMILY / ASSOCIATE PARENT / ASSOCIATE COUPLE**  
membership of the Ballarat Light Car Club and agree, if elected, to be bound by the rules and bylaws of the club.  
( circle the applicable category of membership )

### Current Fees (01/07/05)

Category	Nomination	Annual
<b>Ordinary</b>	\$25.00	<b>\$90.00</b>
<b>Family</b>	\$25.00	<b>\$120.00</b> (2 Parents or Guardians, with any number of own children up to 17y.o or with appropriate dependent student ID)
<b>Associate Family</b>	nil	<b>\$83.00</b> ( 2 non-competing Adults, 1 competing child )
<b>Associate Parent</b>	nil	<b>\$58.00</b> (Parent/Guardian, 1 Child competing)
<b>Associate Couple</b>	nil	<b>\$50.00</b> (2 non competing adults)

Membership Type: \_\_\_\_\_ I enclose membership of \$ \_\_\_\_\_

Occupation / Employer: \_\_\_\_\_

Names of Family Members: Partner: \_\_\_\_\_ Child 1: \_\_\_\_\_ Child 2: \_\_\_\_\_

Child 3: \_\_\_\_\_ Child 4: \_\_\_\_\_

Type of vehicle/s that you will use to compete: Make: \_\_\_\_\_ Model: \_\_\_\_\_

I would like to receive my BULLETIN electronically at my email address above:

Signature: \_\_\_\_\_ Date: \_\_\_\_\_

**Please fill in all details and attach appropriate fees when submitting this form**

We, the undersigned, being members of the Ballarat Light Car Club, wish to recommend acceptance of the above application of the above application for membership. The above named candidate is personally known to us and we believe him/her to be a suitable person to be elected a member of the Ballarat Light Car Club Inc.

Proposer: \_\_\_\_\_ Signature: \_\_\_\_\_ Member No. \_\_\_\_\_

Seconder: \_\_\_\_\_ Signature: \_\_\_\_\_ Member No. \_\_\_\_\_

### Areas of Interest

Please tick if relevant boxes

#### Social

- Clubrooms
- Meetings
- Spectating
- Family Orientated Occasions
- Social Trips

#### Competition

- Circuit Racing
- Special Stage Rallies
- Trials
- Autocross
- Motokhana
- Hillclimb
- Sprints
- Off Road Racing
- Social Motoring / Touring
- Other (specify )

#### Officialling

- Rally / Trial controls
- Event Key Official
- Motorkhana
- Autocross
- Scrutiny
- Directing
- Fire/Rescue
- First Aid
- Flag Marshall
- Timing

#### Office Use Only

Received: / / 20

Fees \$.....

Received

Welcome Letter

Member Number .....

Completed



If undeliverable return to  
**Ballarat Light Car Club**  
PO Box 400  
Ballarat Vic 3353

**The Bulletin**

Print Post Approved

**PRINT  
POST**  
PP325876/00031

**POSTAGE  
PAID  
AUSTRALIA**

