



WHAT'S INSIDE:



Noel Peers President report  
PAGE 3



Calendar of Events  
BLCC  
VCRS  
VRS  
+ More  
PAGE 6



History Slice.  
PAGE 23

February 2011

# The Bulletin

The Official Publication of the Ballarat Light Car Club

## Autocross 1 and Training Day

Trophy Night  
Friday 25th



### News in Brief

#### Wanted Dead or Alive!!

Organising team for the Rd 2 AX on the 6th March. Tag team OK.

Mt Leura Hillclimb on 2nd and 3rd April also needs corner marshals so if you are not competing please put your hand up or pick the

phone up and ring us please.

#### 4WD Eligibility

A Vehicle Eligibility query was submitted to our meeting and the following determination made and the following motion was put that "Four wheel drive vehicles are

in the 4WD Class. End of Story". This motion was duly carried so that's how it will be for 2011.

#### Millard Memorial Trial CTS Status ?

Since the last Sports Subcommittee meeting it has come to

light that the calendar in the Jan Bulletin didn't list the Millard Trial as part of the Club Trials Series even though it had been in the draft Calendar published late last year. If someone has not genuinely not entered because of this mistake please tell Rod Hall as the

*Continued page 10*



# Committee 2010 - 11

## The Bulletin

A monthly newsletter of the  
Ballarat Light Car Club

**Editor:** Steve Ezzy

**E-Mail:** blcceditor@hotmail.com

**Mob:** 0400 160 158

**Contribute:** Contributions can be emailed or posted to 1014 Ring Road Ballarat

**Deadline:** 7 pm Thursday, 8 days prior to monthly club meeting.

## Website Info



<http://blcc.net.au/>

**Webmaster:** Wayne Sleep

**AH:** 5339 4890

**Mobile:** 0419 031 712

**E-Mail:** blccwebmaster@hotmail.com

### President

Noel Peers  
**Property Officer**  
AH: 5341 8124  
Mob: 0408 033 895  
blccpresident@hotmail.com



### Secretary

Ange Ruyg  
Mob:  
blccsecretary@hotmail.com



### Treasurer

Clare Bennett  
AH: 5330 2295  
Mob: 0439 652 325  
bennett@ncable.net.au



### Grants Officer

Assistant Media Liaison  
Officer  
Stacey Noonan  
Mob: 0417 163 193  
staceynoonan@hotmail.com



### Events Secretary

**C.A.M.S Liaison**  
**Sport Sub**  
**Committee Chair**  
Rod Hall  
53313546  
0438 313 546  
rod.hall@ballarat.edu.au



### Sports Sub Committe

Ben McGee  
0438 313546 / 5331 3546  
Barney Haddon  
0437 167 790 / 5335 5112  
Damian Faulkner  
0407 643 803

### CAMS

**Sports Club Development Officer**  
Rob Dunt / 9593 7740

**Permits Administrator**  
David Milne / 9593 7732

### Vice President



**State Council Rep**  
Les Noonan  
AH: 5331 6148  
Mob: 0410 524 139

### Membership Secretary

w.sanders@optusnet.com.au  
Wayne Sanders  
AH: 5334 2330  
Mob: 0412 713023



### House Chairman



**M/sport Cplx Manager**  
**Assistant Property Officer**  
**Hillclimb Panel Rep**  
Barney Haddon  
AH: 5335 5112  
Mob: 0437 167 790  
barno4@bigpond.net.au

### CAMS State, AASA

### Delegate

Ian Brain  
Mob: 0418 518 088  
ibrain@ncable.net.au



### Bulletin Editor



Steve Ezzy  
AH: 5339 4821  
Mob: 0400 160 158  
blcceditor@hotmail.com

*POSITIONS CURRENTLY VACANT*

*RALLY PANEL REPRESENTATIVE*

*JDP Co-ORDINATOR*

*SPONSORSHIP*

# Presidents Report Feb 2011

G'day and welcome to the February issue of BLCC's Bulletin.

Firstly an apology from me! I missed the Feb Committee meeting due to diff failure at Yalata, about 200km west of Ceduna after 1.42 million km crown wheel + pinion came out of mesh after the bearings collapsed.

That's a rebuild, gear and a diff all worn out and only one brake replaced on the prime-mover and only three needing replacement out of twelve on the trailer all in the space of twelve years. Kenworth - Australian Made - worlds best "yes I am one eyed!"

Car Club matters, you miss a meeting and you tend to lose contact with what's going on at the club. Firstly congratulations to Ian Brain and his band of helpers. The Come n Try, Autocross Training day and Autocross rnd 1 on Sunday 13th Feb was huge success buy all accounts. Heaps of people taking part in all parts of the day even if it did run a little bit late.

Thanks to Steve Ezzy for once again taking on the catering organisation and for his daughter Catherine for cooking all day. Steve also took on First Aid after St John's left at six. Thanks to all of the dedicated members who gave up a lot of their own time over the weekend in various roles.

I believe that there were enough people to assist however a few more would have assisted greatly.

There was good publicity in the paper and councillors Sam McIntosh, John Phillips and Cheryl Bromfield was wonderful

Congratulations Ian and a job well done!

Coming events would have included the CVAC round at Kynton however this has been postponed. Our Club Night this month will be our Trophy Night. Cost is on \$5.00 per head for a good supper trophies presented and a good talk by our guest speaker Mr Keith McElroy a Renault tragic and intrepid explorer.

The Millard Memorial is also on the club weekend as well as the Swap Meet. The 6th of March is Autocross Rnd 2 and Seemore Motorsport is running their Uplands Stages in the Wombat in March also.

The end of March sees the Grand Prix at Albert Park and early April the club will be running on of our major events! - The Hillclimb at Mt Leura. On another note a letter was sent to our three ward councillors to try and clarify our position with regards to our tenure at the Airport.

A reply was received from the City of Ballarat which just stated what we already



knew.

- Our Current lease expires on the 30th of June.
- The lease will be renewed on a month by month basis
- We will retain the use of the site for a few years to come.
- There is no definitive date for the end of our tenure
- All of the above relate to our Motorsport Complex and not our club rooms.

The Committee is currently engaged in exploring options that may be available to the club.

See you all at the Trophy Night  
Noel Peer - President

Ps. A late thank-you to Rob Prosser for doing some after hours maintenance at the clubroom.

# Treasurers Report February 2011

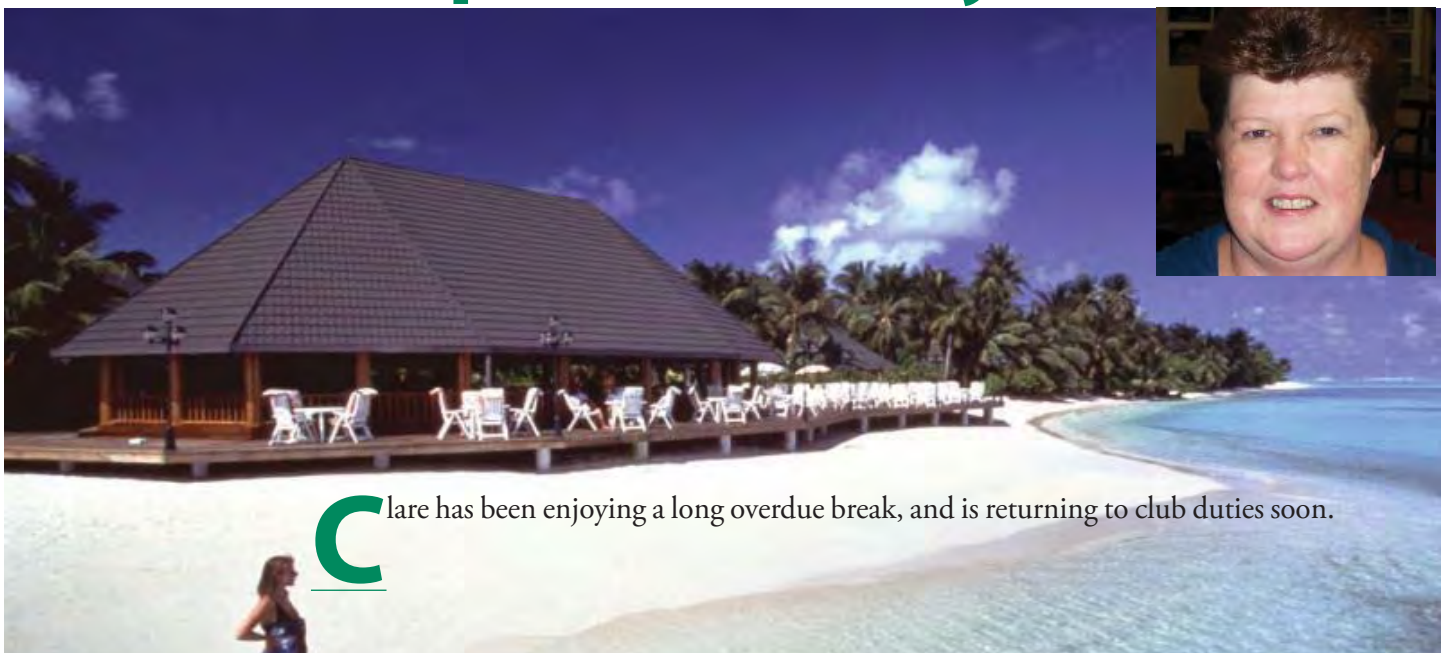

Clare has been enjoying a long overdue break, and is returning to club duties soon.

# In The News

Ballarat Courier Evan Schuurman

14 Feb, 2011 12:36 AM

**B**allarat's young drivers do hot laps CHILDREN as young as 12 years old were given the chance to get behind the wheel yesterday in a first-time initiative by the Ballarat Light Car Club.

About 25 young drivers made the most of the unique driving opportunity, which was designed to help prepare young people to become better drivers in the future.

Each young person was put in the hot seat for the first of two laps of the 1.6km course.

Accompanied by an experienced driver, the young driver then switched to the passenger seat for what was termed the hot lap, which gave the young drivers the chance to experience a drifting vehicle and the thrill of travelling at high speed.

Anna Tuncks, 14, said the second lap was especially fun.



"It was awesome because it was really slippery and we kept drifting," she said.

Rebecca Stephens, 17, who has already begun learning to drive on the road, said the experience would help her become a better driver.

"It's something you don't normally get to learn on the road," she said.

"But here you learn how to regain control of the vehicle."

The driving session was so popular, the BLCC had to delay their afternoon autocross competition so that all the young drivers could have a turn.

The BLCC adhered to Occupational Health and Safety regulations throughout the day. All cars were scrutinised, tested and carried fire extinguishers, and there was an ambulance standing by.

## Proposed BLCC Book

In the last 18 months a dedicated group of members have been working on documenting, copying, collating and recording a tremendous amount of material related to the history of our club. They have met regularly with past members and now have the basis for the creation of a valuable historical book covering the 60 years of our clubs existence.

The principle members of this group have now put out the call for people that may be able to contribute to publication by way of volunteering to complete the sorting of this material which is in an electronic form and physical documents, and the publication of the various sections, ie decades and specialist Motorsport areas, people with experience in IT would also be very useful, however any assistance would be gratefully accepted.



# 2011 Come and Try & Training Day

Ian Brain

**L**ike Julius Caesar and his Centurions, they came, they saw, and they conquered.

The fear of a manual gear change at least was conquered by around 25 beginner drivers on the Club's Motorkhana area at our 2011 Training Day. As well, around 20 people gave Autocross a go for the first time. And three of our City's Councillors were here to support us, including one whose kids got fully immersed in the driver training.

To be frank we got overwhelmed with the response from learners and people wanting to participate on the day. Continuing the frank theme, we could have done with some more helpers, but we coped (just) and people had a fantastic time.

Much appreciation goes to those who did become involved, and by the looks on your faces as well as the newcomers it was a pretty enjoyable day for you as well. If you weren't there, I'm sure you'll hear from someone who was, and so please consider some involvement next time the club runs one of these days. Everybody has something to contribute on days like this, and the rewards – to members as well as the club – are tangible and worth the effort. It's my view that they are critical to the club's longer term future and should



be a regular calendar event. Perhaps even with some rally driver training thrown in.

The club's Autocross advanced driver training was also well attended, with some quite impressive outcomes during the afternoon's Club Autocross Round 1. (see results elsewhere in The Bulletin) – one driver found nearly 10 seconds, another 6, and most others at least 2. So that was ten bucks well spent, hey girls and guys.

Training was capped off by a new approach to Autocross Demonstration

laps, and I will leave final judgement to others, but from my perspective as Director, officials managed and monitored the requirements and accountabilities for this more open approach quite clearly and quite well, and club members who drove were responsible in their driving. We will leave it to Sports Subcommittee to determine if this could be an appropriate way to conduct demonstration laps in the future.



# Event Calendar



## ■ February

### Friday 25th

Trophy Night with Guest Speaker. \$5 door cost.

### Saturday 26th

Millard Memorial Trial, CTS1  
Eildon 1600 Classic Rally

### Sunday 27th

Victorian Hillclimb Championship  
Round 2 Rob Roy  
Millard Memorial Trial, CTS1

## ■ March

### Sunday 6th

BLCC Autocross round 2, CDC1

### Saturday 19th

Uplands Stages, CTS2. Seemore Motorsport

### Sunday 20th

Geelong AX/KX R1 - Autocross

### Friday 25th

BLCC Club Meeting

### Saturday 26th

Rally Bonnie Doon

## ■ April

### Saturday 2nd

Victorian Hillclimb Championship  
Round 3, Mt Leura CDC2  
Berwick Volkswagen Yakkerboo Rally

### Sunday 3rd

Victorian Hillclimb Championship  
Round 3, Mt Leura CDC2  
Geelong Motorkhana round 4

### Saturday 16th

Seemore Stages 1 Seemore Motorsport

### Sunday 17th

Geelong AX/KX R2 - khanacross

### Friday 29th

BLCC Club Meeting

### Saturday 30th

Trailblazer HRA

## ■ May

### Sunday 1st

Central Victorian Autocross Challenge  
round 2 Ballarat (AX3)  
Victorian Hillclimb Championship  
Round 4 PIARC

### Saturday 14th

East Gippsland Stages VRC1

### Sunday 15th

Geelong AX/KX R3 - Autocross

### Saturday 21st

The Italian Connection

### Sunday 22nd

BLCC Autocross Round 4 CDC3

### Friday 27th

BLCC Club Meeting

### Saturday 28th

The Ken Roddnam Memorial Trial

## ■ June

### Saturday 4th

Daryl Tunbridge Trial

### Sunday 5th

BLCC Motorkhana 1 and Khanacross  
Victorian Hillclimb Championship  
Round 5, Ararat

### Sunday 12th

Bega Valley Rally VRC2

### Saturday 18th

Seemore Stages 2, Seemore Motorsport  
Sunday 19th

Winton Sprints CDC4

Friday 24th

BLCC Club Meeting

Saturday 25th

Nissan Nightmoves CTS3, VCRS 2

### Sunday 19th

Geelong AX/KX R4 - khanacross

## ■ July

### Saturday 2nd

Kelly Country Trial, HRA  
BLCC Motorkhana 2 CDC5 and Day  
Night Autocross

### Sunday 3rd

Victorian Hillclimb Championship  
Round 3 Shepparton.

### Saturday 16th

George Derrick Memorial Rally VRC3 -  
CTS4

Sunday 17th

Geelong AX/KX R5 - Autocross

### Sunday 24th

BLCC, Barney's Double Banger Autocross

### Friday 29th

BLCC Club Meeting

### Saturday 30th

Rich River Revisited, HRA

## ■ August

### Saturday 6th

Baden Powell Introductory Trial Rover  
Scout Motorsport

### Sunday 7th

BLCC, Motorkhana 3

### Saturday 13th

Cooper Memorial Rally Sprint

### Sunday 21st

Geelong AX/KX R6- khanacross

### Friday 26th

Winter Classic Rally and Tour  
No Club Meeting

### Saturday 27th

Winter Classic Rally and Tour  
Ivans Folly

### Sunday 28th

Winter Classic Rally and Tour  
Victorian Hillclimb Championship  
Round 7, Haunted Hills

## ■ September

### Saturday 3rd

Mt Porpunkah Rally Spring  
The Lions Rally

### Saturday 10th

Mafeking Mahem

### Sunday 11th

BLCC, Motorkhana 4 CDC6  
Geelong Motorkhana R1

### Saturday 17th

Marysville Stages, VCRS Round 4, CTS6

### Sunday 18th

Victorian Hillclimb Championship  
Round 8 Rob Roy  
Geelong AX/KX R7 - Autocross

### Friday 30th

BLCC Club Meeting

## ■ October

### Friday 7th

Bathurst 1000

### Saturday 8th

Wild Dog Stages CTS7  
Bathurst 1000

### Sunday 9th

Bathurst 1000  
Proposed BBQ and Bathurst day at  
BLCC Clubrooms. (register your interest  
bathurst2011@blcc.net.au)

### Saturday 15th

Akademos VRC4

# Event Calendar continued

## Sunday 16th

Sandown Sprint CDC8  
Geelong AX/KX R8 - khanacross

## Friday 28th

BLCC Club Meeting

## Saturday 29th

Bagshot Rallysprint

## November

### Saturday 5th

Coghlan's Carnival

## Sunday 6th

Coghlan's Carnival  
Geelong Motorkhana R2

## Saturday 12th

Rally Victoria

## Saturday 20th

Reserve Date for BLCC Autocross and Series  
Geelong AX/KX R9 - Autocross

## Friday 25th

BLCC Club Meeting

## Saturday 26th

Alpine Rally

## December

### Saturday 3rd

Ararat One Tree Hillclimb

### Sunday 4th

Ararat One Tree Hillclimb

### Sunday 11th

Geordie Fawcett Memorial Autocross,  
Xmas Breakup  
Geelong Come & try khanacross

## Your Club Get Involved

### CVAC Leader/Organiser

The Central Victorian Autocross Challenge will be on in earnest this year but we need to have someone who would take on the responsibility for co-ordinating the BLCC entrants. Ideally this would be a competitor who would gather other BLCC competitors to travel to and compete in events to ensure we have a team. This would involve ringing around, twisting arms cajoling offering huge sums of folding stuff. This could even be a small group of like minded individuals.

Rather than have 1 person to do all 4 of the CVAC events this could be 4 different people coordinating 1 event each, but if you would like to do all 4 feel free. This person could advise where the tracks are, where and when supps are available, how to get there for the out of town ones. Would also involve organising a meeting point for the BLCC team to meet so they can travel in convoy if desired.

### Doing it for the club

There are often tasks that need completing or some work that needs to be done around the club. More often however we are a time poor lot and there are many other things going on. This does not have to mean that there is nothing that you can do for the club.

Many of us have skills that are useful and can be easily utilised. Computer or IT skills, communications, design, carpentry, driver training fund-raising you name it there is always at some time or another something useful that you can do that does not involve actually doing car stuff. So if you can only cook one barby in a year or do up a page for the Bulletin, service a JDP car or deliver phone books we will value your contribution.

### Some tips for those teaching their kids to drive

When teaching your child to drive, bear the following tips in mind to help them have an enjoyable experience:

- Try to refrain from making comments like 'What are you doing?' as they will put your charge ill at ease and create a bad atmosphere.

- Don't shout orders such as 'Brake now!' as they will also make the young driver nervous.

- Make sure you tell your child at the beginning of the lesson what skills you will be practising today, e.g. parking. This will help them feel prepared.

- Whilst they are driving, calmly comment on the road ahead and point

out any hazards they may encounter.

- Give praise where it's due and also point out things that they have done wrong. Just remember to remain calm!

- Try to pick an area where there is little traffic until your charge feels more confident. Start off with a quiet residential area, and then move to busier areas until the learner can cope with busy town centres and dual carriageways.

- Put emphasis on 'Mirror, signal, manoeuvre' so that this becomes ingrained in the learners mind. Do this for other procedures such as parallel parking.

- Ensure that seat belts are worn at all times and mobile phones are not used.



# autoparts

PROFESSIONALS  
BALLARAT



3" RPM Harness FIA Approved 4PT **Red**, Silver, Black, **Blue** \$249  
 3" RPM Harness FIA Approved 6PT **Red**, Silver, Black, **Blue** \$269  
 2" RPM Harness AS2596 4PT **Red**, Black, **Blue** \$195



Willians Harnesses also now available in **Silver**, **Red**, **Blue** and **Black** \$399



SaBelt 4pt Harness, **Red**, \$445



Sparco PRO ADV Raceseat, \$1395 **IN STOCK!**

Spacro EVO Raceseat \$1099 **IN STOCK!**

Cobra Monaco Raceseat FIA \$495 **IN STOCK!**

KIRKEY Alloy seats from \$269 **IN STOCK!**

JAZ/RPM Plastic Seats from \$119 **IN STOCK!**



RPM Helmets, Best seller for 2009!

RPM Rally Open Face \$399

RPM REV-1 Full Face \$499

RPM PUMPED Force Air \$699

All SA 2005 Approved, Lightweight Composite Shell, Kevlar Strap and Nomex lining, Great value, HANS Ready, all in stock!

BELL Helmets also stocked starting from \$799

HANS Device from \$950 in stock!



RPM Clubsport Single Layer Suit \$299

RPM Club Gloves \$89

RPM Mondial Double Layer FIA Suit \$699

Packages starting from \$849

Mechanics Gloves from \$29.95

Call in and see Nathan and David, for there huge range of stock, 7 days a week, for friendly advise and great prices, supporting the Ballarat light car club for 15 years!

Auto Parts Professionals, 9 Doveton St Nth, Ballarat, 53329333

## Revised Club Permit Scheme

Changes to Victoria's Club Permit Scheme will come into effect on 1 February 2011

### How will it change?

Under the new scheme permit holders will no longer be restricted to club sanctioned activities when using their vehicles. Vehicles will be able to be used at any time for any purpose. However, they will be restricted to a total of 90 days use a year.

Club financial members will be able to apply for either a 90 day permit or a 45 day permit depending on how much use they expect to make of their vehicles over a 12 month period. If a person obtains a 45 day permit but later decides that this is not enough, another 45 day permit may be purchased later on. However, no-one will be allowed to obtain a permit to drive their vehicle for more than 90 days each year.

### How will it operate?

A logbook will be issued to permit holders to record the use of the vehicle over the permit period.

Vehicles will be able to be used without a logbook entry within 100 metres of the vehicle's garage address.

A windscreen label will be issued to assist in the identifying vehicles operating without a current permit.

VicRoads may suspend or cancel a permit if the permit holder fails to comply with the permit conditions or engages in conduct which threatens public safety or undermines the integrity of the permit scheme.

Clubs will be required to sign an Agreement with VicRoads that they meet certain obligations including that they notify VicRoads if they become aware of or reasonably suspect a pattern of incorrect use of a log book by one of its members. If this is not done, VicRoads will be able to revoke the club's approval to be part of the scheme.

### What about inspection standards and vehicle definitions as referred to in last year's Discussion Paper?

It is expected that these changes, which include a new street rod inspection scheme and improved definitions of 'replica' and 'modified' vehicles, will be implemented after February 2011.

### How will the changes be introduced?

In the lead up to February 2011 all current permit holders will be issued with a free 90 day logbook. The logbook will be able to be used until the current permit expires. It can be used for a maximum of 90 days irrespective of the permit expiry date. It will be a requirement that the current permit be carried with the logbook at all times.

No windscreen label will be issued until the current permit is renewed.

### Will there be changes to number plates?

Yes, 'Slim-line' club permit number plates will now be available.



## News in Brief *continued*

SSC Chair and we will discuss it at our next couple of meetings. We don't want to affect those that have entered on the basis that it was supposed to be part of the CTS so please talk to Rod if it's a drama so we can discuss it at future meetings.

### Club Historian

The committee is calling for expressions of interest from persons interested in becoming the club historian.

### Log Books

All competing cars must present with either a "Club" log book or one issued by CAMS.

### Good News

CAMS now permit you to use FAI approved seat belts with "valid to" dates for a further 5 years. For example "Valid To December 2008" can be used up to December 2013.

### Club Points Compiler

We are **still** searching for someone to take on the role of Club Points Compiler. If you are interested in filling this position please contact a committee member. Please note if someone does not step up to fill this position the CDC etc will go un-scored this means no trophies.

### Western Link Road

The Ballarat Western Link Road would connect the Western Highway near the Ballarat Airport and the Midland Highway to the south of Sebastopol. It would serve new developments at the Airport precinct and residential developments in Ballarat West and would be approximately 16 kilometres long. Recent studies have identified a preferred alignment that is two lanes wide in each direction from Glenelg Highway to the Western Highway in the north, and one lane wide in each direction from Glenelg Highway to Midland Highway in the south. However, transport modelling has shown that the ultimate road configuration as described above would not be required until 2031.

# ROBSON GLASS

Established over 98 years

- Shop Fronts
- Broken Glass Replacement
- 24hr Emergency Service
- Cut To Size Glass & Glazing
- Insurance Work
- Lead Lighting
- Mirrors
- Safety & Sound Proof Glass
- Glass Splashbacks
- Shower Screens
- Double Glazing



W J ROBSON & SONS PTY LTD  
**5332 2078 MBL 0418 508 429**  
After Hours 5341 3898 or 5339 4664  
Cnr Maun Rd & Humffray St Ballarat



**Liability Disclaimer** – All material in this magazine represents the opinions of the authors and does not carry any endorsement by the Editor or the Committee, Ballarat Light Car Club has no official connection with any public or commercial organisation and it does not provide product recommendations. Names of commercial products mentioned in this magazine are registered names and trademarks of their owners. Copyright Notice – Material in this magazine may be copied by any other club without fee or written permission provided that the copyright rests with the Ballarat Light Car Club. The copies are not to be used for commercial advantage and the origins of the material and this permission to copy are acknowledged in the reprinted item. The Nissan Car Club-Australia is acknowledged as the source for the wording of this Disclaimer.

# Autocross & Training Day



## BLCC 2011 Autocross Series Round 1 - Provisional Results



### Classes Results 13/02/2011

No	Name	Car	Class	Prac	Hats	Run1	Hat	Run2	Hat	Run3	Hat	Run4	Hat	Total	OR	Class
<i>Standard under 1800cc</i>			<b>A</b>													
3	Stefan Dekker	MR2	A	99.731	0	88.074	0	86.425	0	92.958	0	86.432	0	260.931	19	1
1	Robert Dekker	Laser	A	200.000	0	91.634	0	88.966	0	88.831	0	88.013	0	265.810	22	2
4	David Jowett	Pulsar	A	97.010	1	91.484	0	88.383	0	88.781	0	88.998	0	266.162	23	3
2	Marc Salter	Laser	A	200.000	0	92.049	0	92.755	0	93.356	0	92.392	0	277.196	29	4
6	David Eden	Corolla	A	98.466	0	94.517	0	91.665	0	91.292	2	91.864	0	278.046	31	5
<i>Standard over 1800cc</i>			<b>B</b>													
11	Robert Schenk	Laser	B	88.979	0	87.899	0	86.013	0	85.807	0	85.106	0	256.926	11	1
9	David Marmo	Falcon	B	91.190	0	90.908	0	88.89	0	91.441	1	88.484	0	268.282	24	2
12	Greg Park	Peugeot 504 TI	B	94.778	0	91.89	0	92.56	0	94.042	0	92.202	0	276.652	28	3
8	Jim Hammond	Falcon	B	96.828	1	93.257	1	92.966	0	95.389	0	91.597	0	279.952	32	4
10	Matthew Davies	Escort	B	100.602	2	105.943	0	95.833	0		0		0	401.776	52	5
<i>Modified up to 1800cc</i>			<b>C</b>													
19	Ben Davis	Corolla	C	84.895	0	85.256	0	86.632	0	85.949	0	86.392	0	257.597	14	1
16	Harry Ansell	Datsun 180B	C	87.136	0	87.701	0	86.818	0	86.904	0	87.069	0	260.791	18	2
21	Reg Johnson	Galant	C	88.091	0	87.545	0	200	0	91.036	0	90.051	0	268.632	25	3
7	Evan Dekker	Sprinter	C	92.028	0	94.924	0	91.131	1	89.422	1	90.868	0	280.214	33	4
17	Henk Dekker	Sprinter	C	91.684	0	93.627	1	93.078	0	100.595	0	93.665	0	285.370	40	5
18	Mark Hunter	Colt 45	C	92.455	0	102.097	0	93.354	0	93.839	0		0	289.290	42	6
15	Josh Davis	Corolla	C	92.670	0	91.758	0	91.669	0		0		0	383.427	51	7

## BLCC 2011 Autocross Series Round 1 - Provisional Results



### Classes Results 13/02/2011

No	Name	Car	Class	Prac	Hats	Run1	Hat	Run2	Hat	Run3	Hat	Run4	Hat	Total	OR	Class
<i>Modified over 1800cc</i>			<b>D</b>													
24	Ian Brain	Peugeot	D	88.046	0	89.502	0	86.453	0	85.712	0	85.284	0	257.449	12	1
26	Craig Latta	Peugeot 505	D	96.380	0	91.117	0	92.551	0	91.856	0		0	275.524	27	2
22	John Welford	Peugeot 504	D	93.795	0	94.158	0	94.311	0	95.918	0	200	0	284.387	39	3
23	Peter Stapleton	Datsun 200B	D	92.563	0	92.672	0	98.458	0	95.129	0		0	286.259	41	4
<i>Four Wheel Drive</i>			<b>F</b>													
31	Ben McKee	Subaru Liberty	F	80.286	0	80.178	0	80.426	0	79.466	0	79.479	0	239.123	1	1
27	Ash Findlay	Subaru WRX STI	F	81.087	0	80.257	0	81.102	0	82.4	0	82.411	0	243.759	2	2
36	Keith McElroy	Subaru WRX STI	F	81.053	0	82.118	0	81.685	0	81.395	0	81.64	0	244.720	3	3
28	Michael Goossens	Subaru RX	F	225.771	0	83.966	0	83.574	0	83.646	0	83.924	0	251.144	5	4
34	Russell McKenzie	Subaru WRX	F	86.312	0	84.358	0	85.426	0	84.32	0		0	254.104	7	5
35	Keith Scott	Subaru WRX	F	85.502	0	86.598	0	85.811	0	84.097	0	84.861	0	254.769	8	6
30	Arron Secombe	Mazda Familia	F	86.265	0	84.879	0	87.333	0	86.767	0	84.483	0	256.129	9	7
32	Les Baxter	Magna	F	87.159	0	86.261	0	85.458	0	85.877	0		0	257.596	13	8
29	Les Noonan	Mazda Familia	F	88.881	0	86.358	0	85.5	0	86.733	0	85.915	0	257.773	16	9
<i>CH Plate Registered</i>			<b>H</b>													
40	Leon Pegg	Gemini	H	86.248	0	85.912	0	87.15	0	86.782	0	84.941	0	257.635	15	1
41	Robert Prosser	Celica	H	90.873	0	90.792	0	91.082	0	94.144	1	95.791	0	277.665	30	2
20	Chris Stevens	Corolla	H	93.203	0	95.219	0	93.403	0	92.97	0	93.911	0	280.284	34	3
37	Simon Francis	Gemini	H	97.913	0	89.157	0	92.172	1	89.511	1	100.803	0	280.840	35	4
50	Elizabeth Gilholme	Gemini	H	92.953	0	95.242	0	95.561	0	92.409	0	101.05	0	283.212	37	5

Continued Next Page

# BLCC 2011 Autocross Series Round 1 - Provisional Results



## Classes Results 13/02/2011

No	Name	Car	Class	Prac	Hats	Run1	Hat	Run2	Hat	Run3	Hat	Run4	Hat	Total	OR	Class
<i>Specials</i>			<b>I</b>													
43	Dan Hall		I	85.332	0	84.202	0	83.188	0	83.032	0	83.716	0	249.936	4	1
33	Chris Hall		I	86.864	0	84.142	0	84.803	0	84.913	0	84.598	0	253.543	6	2
44	Garry Harrowfield	Porsche	I	87.924	0	86.678	0	86.499	0	85.249	0		0	258.426	17	3
42	LesListon	Lancia Beta	I	95.678	0	90.344	0	90.016	0	92.239	0	92.149	1	272.599	26	4
<i>Juniors 14-16 Years</i>			<b>J2</b>													
49	Craig Hunter	Bluebird	J	86.969	0	87.579	0	86.708	0	88.155	0	87.249	0	261.536	20	1
48	Brayden Hammond	Falcon	J	100.697	0	99.599	0	97.962	0	98.932	0	98.939	0	295.833	43	2
47	Dean Ansell	Datsun 180B	J	103.750	0	105.102	0	97.866	0	99.926	1	98.982	0	301.774	44	3
54	Ben Park	Peugeot 504 TI	J	110.873	0	101.949	0	106.979	1	104.07	1	95.113	0	306.132	46	4
13	Nathan Stevens	Laser	J	112.214	1	111.375	0	107.174	0	117.637	0	107.009	0	325.558	49	5
5	Nathan Latta	Peugeot 505	J	89.421	0	96.286	0	118.134	2	103.921	1		0	333.341	50	6
<i>Juniors 16-18 Years</i>			<b>J3</b>													
53	Scott Hunter	Bluebird	J	86.956	0	85.481	0	84.924	0	86.326	1	85.756	0	256.161	10	1
57	Trent Ansell	Datsun 180B	J	101.000	0	102.786	2	102.042	0	102.097	0	96.909	1	306.048	45	2
55	Sam Black	Corolla	J	102.646	0	108.537	0	98.202	1	98.313	1	100.071	0	306.586	47	3
<i>Ladies</i>			<b>L</b>													
58	Stacey Noonan	Mazda Familia	L	91.559	0	89.065	0	88.668	0	87.273	0	88.453	0	264.394	21	1
61	Sharon Pitt	Corolla	L	96.718	0	93.418	0	93.869	0	94.352	0		0	281.639	36	2
60	Kate Meyer	Bluebird	L	94.059	0	94.12	0	96.481	0	95.919	0	93.441	0	283.480	38	3
59	Bronwyn Salter	Corolla	L	108.632	0	107.052	0	102.957	0	104.413	0	102.062	0	309.432	48	4



**Mechanica Industries**  
design · create · repair · salvage

- Mechanical engineering
- Automotive maintenance & repairs
- Machine shop
- On-site maintenance

*If its metal, we can design it, create it, repair it or salvage it.  
At Mechanica Industries, we love machines!*

Mechanica Industries are located at **12 Paddys Drive Delacombe 3356**

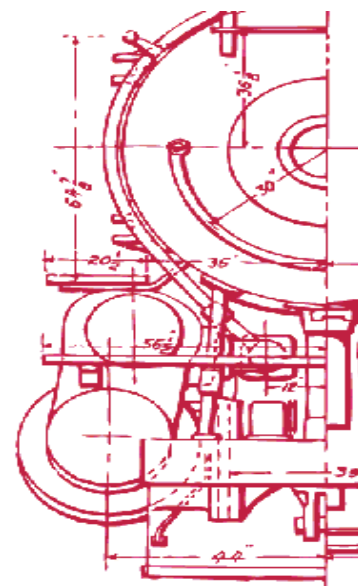

[www.mechanicaindustries.com.au](http://www.mechanicaindustries.com.au)

**5335 7251**

**M**embers listed below have nominated themselves as being willing to assist fellow members

**Ian Brain** (expert in restorations and pressed metal ceilings) - 0418 518 088 or 5332 2828

**Peter Ellis** (Driving Ambition) Driver Training Specialist to Individuals and Business -  
Mobile 0419 002 007 Tel. (03) 5334 3144

# BLCC 2011 Autocross Series Round 1 - Provisional Results

## Outright Results

13/02/2011



No	Name	Car	Class	Prac	Hats	Run 1	Hats	Run 2	Hats	Run 3	Hats	Run 4	Hats	Total	OR	Class
31	Ben McKee	Subaru Liberty	F	80.286	0	80.178	0	80.426	0	79.466	0	79.479	0	239.123	1	1
27	Ash Findlay	Subaru WRX STI	F	81.087	0	80.257	0	81.102	0	82.4	0	82.411	0	243.759	2	2
36	Keith McElroy	Subaru WRX STI	F	81.053	0	82.118	0	81.685	0	81.395	0	81.64	0	244.72	3	3
43	Dan Hall		I	85.332	0	84.202	0	83.188	0	83.032	0	83.716	0	249.936	4	1
28	Michael Goossens	Subaru RX	F	225.771	0	83.966	0	83.574	0	83.646	0	83.924	0	251.144	5	4
33	Chris Hall		I	86.864	0	84.142	0	84.803	0	84.913	0	84.598	0	253.543	6	2
34	Russell McKenzie	Subaru WRX	F	86.312	0	84.358	0	85.426	0	84.32	0		0	254.104	7	5
35	Keith Scott	Subaru WRX	F	85.502	0	86.598	0	85.811	0	84.097	0	84.861	0	254.769	8	6
30	Arron Secombe	Mazda Familia	F	86.265	0	84.879	0	87.333	0	86.767	0	84.483	0	256.129	9	7
53	Scott Hunter	Bluebird	J3	86.956	0	85.481	0	84.924	0	86.326	1	85.756	0	256.161	10	1
11	Robert Schenk	Laser	B	88.979	0	87.899	0	86.013	0	85.807	0	85.106	0	256.926	11	1
24	Ian Brain	Peugeot	D	88.046	0	89.502	0	86.453	0	85.712	0	85.284	0	257.449	12	1
32	Les Baxter	Magna	F	87.159	0	86.261	0	85.458	0	85.877	0		0	257.596	13	8
19	Ben Davis	Corolla	C	84.895	0	85.256	0	86.632	0	85.949	0	86.392	0	257.597	14	1
40	Leon Pegg	Gemini	H	86.248	0	85.912	0	87.15	0	86.782	0	84.941	0	257.635	15	1
29	Les Noonan	Mazda Familia	F	88.881	0	86.358	0	85.5	0	86.733	0	85.915	0	257.773	16	9
44	Garry Harrowfield	Porsche	I	87.924	0	86.678	0	86.499	0	85.249	0		0	258.426	17	3
16	Harry Ansell	Datsun 180B	C	87.136	0	87.701	0	86.818	0	86.904	0	87.069	0	260.791	18	2
3	Stefan Dekker	MR2	A	99.731	0	88.074	0	86.425	0	92.958	0	86.432	0	260.931	19	1
49	Craig Hunter	Bluebird	J2	86.969	0	87.579	0	86.708	0	88.155	0	87.249	0	261.536	20	1
58	Stacey Noonan	Mazda Familia	L	91.559	0	89.065	0	88.668	0	87.273	0	88.453	0	264.394	21	1
1	Robert Dekker	Laser	A	200	0	91.634	0	88.966	0	88.831	0	88.013	0	265.81	22	2
4	David Jowett	Pulsar	A	97.01	1	91.484	0	88.383	0	88.781	0	88.998	0	266.162	23	3
9	David Marmo	Falcon	B	91.19	0	90.908	0	88.89	0	91.441	1	88.484	0	268.282	24	2
21	Reg Johnson	Galant	C	88.091	0	87.545	0	200	0	91.036	0	90.051	0	268.632	25	3
42	LesListon	Lancia Beta	I	95.678	0	90.344	0	90.016	0	92.239	0	92.149	1	272.599	26	4
26	Craig Latta	Peugeot 505	D	96.38	0	91.117	0	92.551	0	91.856	0		0	275.524	27	2
12	Greg Park	Peugeot 504 TI	B	94.778	0	91.89	0	92.56	0	94.042	0	92.202	0	276.652	28	3
2	Marc Salter	Laser	A	200	0	92.049	0	92.755	0	93.356	0	92.392	0	277.196	29	4
41	Robert Prosser	Celica	H	90.873	0	90.792	0	91.082	0	94.144	1	95.791	0	277.665	30	2
6	David Eden	Corolla	A	98.466	0	94.517	0	91.665	0	91.292	2	91.864	0	278.046	31	5
8	Jim Hammond	Falcon	B	96.828	1	93.257	1	92.966	0	95.389	0	91.597	0	279.952	32	4
7	Evan Dekker	Sprinter	C	92.028	0	94.924	0	91.131	1	89.422	1	90.868	0	280.214	33	4
20	Chris Stevens	Corolla	H	93.203	0	95.219	0	93.403	0	92.97	0	93.911	0	280.284	34	3
37	Simon Francis	Gemini	H	97.913	0	89.157	0	92.172	1	89.511	1	100.803	0	280.84	35	4
61	Sharon Pitt	Corolla	L	96.718	0	93.418	0	93.869	0	94.352	0		0	281.639	36	2
50	Elizabeth Gilholme	Gemini	H	92.953	0	95.242	0	95.561	0	92.409	0	101.05	0	283.212	37	5
60	Kate Meyer	Bluebird	L	94.059	0	94.12	0	96.481	0	95.919	0	93.441	0	283.48	38	3
22	John Welford	Peugeot 504	D	93.795	0	94.158	0	94.311	0	95.918	0	200	0	284.387	39	3
17	Henk Dekker	Sprinter	C	91.684	0	93.627	1	93.078	0	100.595	0	93.665	0	285.37	40	5
23	Peter Stapleton	Datsun 200B	D	92.563	0	92.672	0	98.458	0	95.129	0		0	286.259	41	4
18	Mark Hunter	Colt 45	C	92.455	0	102.097	0	93.354	0	93.839	0		0	289.29	42	6
48	Brayden Hammond	Falcon	J2	100.697	0	99.599	0	97.962	0	98.932	0	98.939	0	295.833	43	2
47	Dean Ansell	Datsun 180B	J2	103.75	0	105.102	0	97.866	0	99.926	1	98.982	0	301.774	44	3
57	Trent Ansell	Datsun 180B	J3	101	0	102.786	2	102.042	0	102.097	0	96.909	1	306.048	45	2
54	Ben Park	Peugeot 504 TI	J2	110.873	0	101.949	0	106.979	1	104.07	1	95.113	0	306.132	46	4
55	Sam Black	Corolla	J3	102.646	0	108.537	0	98.202	1	98.313	1	100.071	0	306.586	47	3
59	Bronwyn Salter	Corolla	L	108.632	0	107.052	0	102.957	0	104.413	0	102.062	0	309.432	48	4
13	Nathan Stevens	Laser	J2	112.214	1	111.375	0	107.174	0	117.637	0	107.009	0	325.558	49	5
5	Nathan Latta	Peugeot 505	J2	89.421	0	96.286	0	118.134	2	103.921	1		0	333.341	50	6
15	Josh Davis	Corolla	C	92.67	0	91.758	0	91.669	0		0		0	383.427	51	7
10	Matthew Davies	Escort	B	100.602	2	105.943	0	95.833	0		0		0	401.776	52	5



## Ballarat Festival of Motoring

20 - 25 April 2011



### Ballarat hosts motor race revival at Easter

The 50<sup>th</sup> anniversary of a unique International motor race meeting will be celebrated in Ballarat over the Easter weekend, 2011. The Ballarat Festival of Motoring will commemorate the running of the Victoria Trophy race held on 11<sup>th</sup> and 12<sup>th</sup> of February 1961 at the Ballarat air field. Over that memorable weekend Ballarat in central Victoria reverberated to the sight and sound of Formula 1 racing cars racing in an International race meeting organized by the Melbourne and Ballarat branches of the Light Car Club of Australia.

The meeting was graced by the presence of BRM, Lotus and Cooper factory cars driven by Formula 1 stars Dan Gurney, Graham Hill, Ron Flockhart and Innes Ireland and supported by local open wheeler stars Stan Jones, Lex Davison, Austin Miller, Bib Stillwell, Alec Mildren, Jon Leighton and John Roxburgh.

They were backed up by a program of racing which included touring and sports car legends Norm Beechey, Bob Jane, Bryan Thompson, Harry Firth, John Fish, Jim McKeown, David McKay and Murray Carter.

Thousands of motoring enthusiasts from all over Australia are expected to attend the five day **Ballarat Festival of Motoring** celebration, which runs from 20-24 April. Events will include an Historic motor show, a reunion dinner with many of the 1961 drivers present and appropriate guest speakers, a show and shine display at the Ballarat Polo field on Easter Saturday. The highlight will be the track activities at the Ballarat airfield on Easter Sunday April 24, including regularity runs and parade laps using as much of the 1961 track as is possible. In addition, a section of the airfield has been set aside for timed sprints.

These events are open to CAMS certified historic racing and sports cars of the period.

Great support has been received from the Ballarat community, particularly the City of Ballarat council and the Ballarat Light Car Club, so visitors can be assured of a warm welcome for the celebrations. The organizing committee is headed by local Ballarat motoring identity John Emery together with Gary Grant, former organizer of the famous Geelong Eastern Beach sprints, supported by a number of experienced motor sport organizers.

Further information and entry details will be available from the event web site, [www.ballarat.vic.gov.au](http://www.ballarat.vic.gov.au) from late February 2011

For further information contact **John Emery**, 0408 570217, [johnkemery@bigpond.com](mailto:johnkemery@bigpond.com)

### Ballarat Festival of Motoring

*John K Emery 701 Winter Street Buninyong Vic 3357*

*T (03) 5341-2524 M 0408 570217*

*E [johnkemery@bigpond.com](mailto:johnkemery@bigpond.com)*



**6. Sub-committee Reports:**

**a) Sports Sub-Committee:**

- As per report presented;
- Kyneton CC not doing CVAC on date that has been applied for (26/2/11) it shall be re-scheduled once they have more volunteers on committee
- 4WD rule interpretation. Discussion. Confirmed Committee happy with wording.
- Open up Come & Try demonstration drivers to more experienced drives. Discussion. MOTION: LN moved that we remove the roll-cage clause out of this section of rides and start to open up the list of available training instructors. Moved: LN. 2<sup>nd</sup>: SE. Vote: For – 3, Against – 0, Abstained - 2

**b) Hillclimb Committee:**

- Tabled in SSC notes re: past events results

**c) State Council:**

- State Council invites Presidents to next meeting
- IB motioned to this meeting re communication with Clubs/members via website only. Put to a vote, unanimously to be put to CAMS National for review

**d) Club Events:**

**Past Events:**

- Covered in SSC notes

**Coming Events:**

- Come & Try Day: 4 tables for different entry points

**e) New members**

- Nil

**f) General Business**

SE:

- Concern that front lock to be removed during club night meetings and functions to allow fire exit

IB:

- Letter of club's concern sent to Council. Meeting held the night of which our letter was received. Questions were raised by Councillors of Officer's who presented on this topic. Officers have been instructed as a result of letter to call a meeting with BLCC and Councillors within one month. Anticipate a response to come through PO Box.

RH:

- 2 large display cabinets available to BLCC as permanent loan though the cabinets will remain property of the Hall Family . Adjournment to view cabinets. Offer of loan of cabinets as above. Discussion
- IB moved that BLCC accept the generous offer and confirm in writing the conditions of the loan. 2<sup>nd</sup>: SN. AR – to issue letter confirming above conditions
- Knows of a 1500 Datsun Ute available for sale from a man in Kyneton. Needs new battery. IS after \$;s to the value of scrap if anyone interested. Committee decided we don't need another asset to maintain. Thanks, but decline offer.
- Where are we at with the new fire truck? NP is looking after this. Need to be organised for Hill climb @ Camperdown: BH & SE
- Potentially require internet access at Clubrooms and tower for use of events. RH to investigate

BH:

- Good meeting Friday night: good discussions amongst Club members re:future home of BLCC and on-going discussions with Council
- Hot water service has arrived

SN: Nil

LN: Nil

Items raised for future thought/discussion MARCH AGENDA ITEM:

- Selling of Monte Carlo trophy?
- Space taken up by pool table in clubrooms

### **Formula One International Race Meeting**

- Easter April 23-24 2011
- Track inspection conducted Friday 6.2.11 (runway)
- BLCC will need to provide track officials for facilitation of event (see attached flier for further info)
- LN to continue communication on behalf of BLCC with the organising committee re: this event

**Meeting closed 10.25pm**

**Next meeting Monday 14<sup>th</sup> March this is a public holiday. Please advise Secretary if you will not be available on this date**

AR to issue letter to Hall family confirming terms of loan as included in minutes

BH & SE to follow up and make sure fire truck ready for Camperdown

RH to investigate options to have internet access at tower and clubrooms for use during events

AR to place on March agenda

LN to continue to keep BLCC updated on this event

**ALL – Advise to Secretary via email if you can attend next Committee meeting on 14.2.11 as this is a public holiday**

## CTC Series Competitors: Early Entry

This year, the general lack of rallies is causing events to fill up fast. To make sure you get a run, you will need to enter quickly when entries open.

The Sport Sub Committee has decided not to remove events from the CTC Series if someone misses out, unless they have entered within 10 days of entries opening for that event and been refused

**WEBB ALL TRADES** **WEBB SIGNS**

**House & Home**

- House Renovations & repairs
- Plasterboard Hanging & Finishing
- Floor & Wall Tiling
- Concreting. Shed slabs, path's, driveways
- Tree felling & lopping
- Any size job
- Quality work
- Upholstery coming soon!

**Signs & Graphics**

- Race & Rally Signage
- Magnetic Signs
- Boards, Banners & A Frames
- Shop front & Business signage

**Vehicles**

- Competition car preparation, Panel beating & Spray painting
- Welded Rollcages to Cams specs
- General welding (Cert. 8G) & fabrication.

**Wayne & Angela Webb**  
**10 Frawleys Rd, Leigh Creek, 3352**  
**PH: 53 347698 OR MOB: 0438 347 698**  
**Email: webballtrades@westnet.com.au**

## Sport Sub Committee

Rod Hall (Chair) Barney Haddon, Ben McKee, Darren Wythe (Rally Liason), Damian Faulkner, Steven Richards, Wayne Sleep, David Marmo, Peter Marmo, Ben Divis.

Meetings: Wednesday night immediately prior to monthly committee meeting.

## CH and H Plated Cars

From December 1st 20?? A small fee of \$5 will be charged for new and renewal registrations. Chris Hall will collect this when he signs your form. Special use vouchers will also cost \$5. These vouchers must be used when you drive your car for any purpose other

than a BLCC calendared event. The BLCC recently became a member of the Association of Motoring Clubs. The AOMC is working closely with Vicroads on the scheme to introduce a 90 day log book (with a 54 day option). In order to have an input and to be kept informed of the latest

news we needed to join this club. To cover the costs of this membership and the vouchers it has been necessary to impose this small fee. If you have any questions please contact Chris on 5342 4397 or 0438 094 684.

Club Driving Instructors					
John	Bourke	Wayne	Drew	Rod	Hall
Richard	Gay	Gary	Harrowfield	Barney	Haddon
Mick	Goossens	Engels	Leoncini	Peter	Ellis
Les	Liston	Simon	Ellis	Darren	Wythe
Darren	Everett	Ben	McKee	Steve	Richards
Damian	Faulkner	Russell	McKenzie	Mark	Fawcett
Ben	Fawcett	Steve	Wilson	Chris	Hall
Keith	McKelroy	Ben	Davis		

# Membership



**T**his month we welcome to the Club.

ANNE SCOTT, wife of Graeme. Anne owns the car that Graeme competes in so she needs to be a member.

ROGER CURTIS-HARDING. Roger drives a very neat early model V8 Commodore and is keen to do some track days.

There were also several enquiries on the come and try day.

Speaking of the come and try day, from where I sat, up to my ears in paperwork for about five hours it was a raging success. I haven't seen that many

people and cars at the track for a long time. Congratulations to Ian Brain for directing the event which caught us all a little by surprise with the numbers that participated. Steve Ezzy said that he had sold over 100 dim sims as well as most other food by early afternoon!.

There were 25 one day licences, 43 Autowcrossers, 4 one day members from the Peugeot Club and many trainees and riders. A very successful day.

As for my fleet of cars, the Lancer is waiting to finalise its club rego and the Supra is just waiting, parts, paint, money etc, etc you know how it goes.

Anyway, see you at the Club. Regards to all Wayne.



**A** reminder for all email recipients of this publication, please keep your email address current with the membership secretary.

Wayne Sanders  
Email: w.sanders@optusnet.com.au

Phone:  
AH: 5334 2330  
Mob: 0412 713023



## 2011 Hillclimb Calendar

**C**alendar for 2011

- Round 1 – GCC -29th Jan
- Round 2 - MGCC – 27th Feb
- Round 3 – BLCC Mt Leura – 3rd April
- Round 4 - PIARC 1st May
- Round 5 – Ararat CC One Tree Hill ( Clubman or open wheelers excluded) -5th June
- Round 6 – SDCC DECA (to be confirmed) – 3rd July
- Round 7 – VMCI Haunted Hills F8 28th August
- Round 8 – MGCC 18th September

## Getting Social

Stay informed join us on FaceBook and Twitter



Ballarat Light Car Club



BallaratLightCC

# Sports Sub Committee **January 2011**



**G**eordie Fawcett Memorial Autocross – Big field of 50 Entries – Track was Dry, Wet then dry. Track was fast on last lap. Good day was had by all. Comment noted that need to get results downstairs during the event. Been spoilt by Shenky's program at recent events that was missed on this

occasion. The novelty events went OK with most people joining in with the spirit and seemed to enjoy them. Mark Fawcett to be congratulated as he did a really good job as Director.

Ben Davis has started making boards for trophy catch up. SSC will try to get all the unrepresented trophies awarded in 3 months so please make sure you keep turning up on a Friday night.

Please make special note of the following date change : Autocross RD2 and CDC RD1 is now on 6th March because the State Championship Hillclimb at Mt Leura is on the first Weekend in April 2nd and 3rd. This

was because the Hillclimb panel gave us that date. .

Sat 19th March CTS2 Seemore Uplands Stages – Wombat Forest

The BLCC Driver Training List had the following additions made:

Murray Rogers, Ian Brain, Les Noonan, Paul Mahony, Rod Greenwood, Greg Pitt.

NB further additions can be made at any time. Just ask someone on the Sports Sub-committee.

## **B**LCC Trophy Night Feb 2011

The following BLCC members are invited to attend with requisite wheel barrow to pick up their various trophies from competition in various series in 2010

Simon Ellis, Ian Ellis, Paul Williams, Jeremy Egan, Stephen Wilson, Kate Meyer, Ben McKee, Chris Hall, Glenn Latter, Robert Dekker, David Marmo, Michael Goossens, Darren Wythe, Daniel Hall, Robert Schenk, Daniel Kierce, Peter Seid, Craig Hunter, Scott

Hunter.

The rest of us are invited to attend to applaud and clap their endeavours. We also will be given the opportunity to listen to Ten Time BLCC Club Driver Champion Keith McElroy expound on what to drive to Cape York. Keith will tell us of his preparation for such a journey and how he used his motorsport experience during this preparation. Should be a good yarn as to why he chose such vehicle? Come along and see why this is significant.

AX Training Session huge success!! If you want the cheapest modification going around talk to Scott Hunter. For the entry fee for the training offered before the recent Autocross he managed to make huge improvements to his Autocross times sneaking into the top ten of a field of over 40 with a time improvement of around 5 seconds. Such an improvements would normally run up some serious dollars in vehicle modifications and improvements.

## *2010* **Trophy Night**

### **B**reaking News - BLCC Trophy Night 26 Feb 2011

This years Trophy Night will be an exciting but informal affair. BLCC committee has committed to making this night an occasion for all and will organise finger food and light snacks for the evening.

To make the evening more relaxed and informal, committee have declared it “meeting free” zone dedicated to celebrating the successes of members in 2010

The cost will be just 2 dollars more that the usual club night door charge (\$5.00) winners can be determined by the CDC and CTC results published in the Bulletin

## Proposed Members Business Register

I was pondering how I was going to find someone to complete the removal of a huge amount of Wisteria from my side fence. I considered the phone book for a moment and as I did so I thought about who in the BLCC might know someone from the club who knew someone? I was then prompted to think about the amount of useful information that could be collated into a list of useful business / skills / hobbies that people have, do or run.

To this end I thought I might put my idea out there, I will collect a list of members (proposed to me) of people who are likely to be useful to other members. I do not propose that there be any discounts or freebies just a list of people and their field of expertise.

So, if you make stickers, weld up roll cages, are an expert in suspension, electronics, gardening, office supplies, sell bolts, make trailers, are a retired business man willing to offer advice, are an expert in IT or lay cement than you should be on this list.

If you would like to be on this list (Name, Number and field) then SMS or Phone me Steve Ezzy 0400 160 158 or email blcceditor@hotmail.com

<b>Notice to Bulletin Advertisers</b> If you wish to place an advertisement, please consult the Treasurer, <b>Clair Bennett</b> (5330 2295 or 0439 652 325) who will arrange an invoice and pass the request to the Editor, <b>Steve Ezzy</b> , for inclusion in the appropriate issues. Please see the table below for the Annual Fee for Advertising		
Size	Annual Fee (\$)	1 Month Fee (\$)
Full Page	220	22
Half Page	143	14.30
Third Page	119	11.90
Quarter page	99	9.90
Sixth Page	89	8.90
Eighth page	79	7.90

Member Small adverts of the Buy, swap & Sell type will continue to be **Free**

## Club Scrutineers

Chris Hall	Grade 2	5342 4397 0438 094 684
Noel Peers	Grade 3	5341 8124
Darren Wythe	Grade 3	0448 417 506
Ben McKee	Grade 3	5336 1172 0418 313 695
Wayne Webb	Grade 3	5334 7698

### Leaving the complex after Scrutineering

If a competition vehicle needs to leave the motor sport complex, you must remove your numbers so the Police or Vic Roads don't nab you. Also the vehicle needs to be re-presented for scrutiny upon its return before continuing competition.



## Editorial

I went out to assist in the setting up of the event last weekend on Saturday and started at this stage to worry that there would be anyone there on Sunday. I was 2nd or 3rd to arrive on Sunday and was more concerned with setting up for lunch than anything else. By the time I stuck my head out again a little time later I was very pleased to see that it was starting to look like the crowd at a local footy match. There were many members there and many young people and their parents and I was very happy to see local councillors and a few members that I had not seen for a while. A huge pat on the back well earned by the folks who brought out their cars or instructed etc and a big well done to Ian Brain.



## Ellis is at home with his car and club

Stuart McLagan

Ballarat Courier 1998

**W**ith a motor sport background dating back to his childhood, Ballarat Light Car Club Member Peter Ellis was last week named clubman of the year for his organisational activities. Ellis's interest in motor sport developed through his father who was into rallying at local and international levels, including a 10-year stint as a Ford factory driver.

At the age of 18 Ellis began his motor sport career on motorcycles in road and outback endurance events. At about 21, Ellis swapped to rallying in cars. While involved in club level competition right through his rallying days, Ellis has changed from competing in events to organising and running them.

"It is a way of putting something back into the sport," Ellis said. Having first run controls with his parents, then his friends, Ellis became involved in of events through desert rallies while looking at riders' safety.

Since 1990 Ellis has been Clerk of Course for the Golden Mile Hillclimb and last year took on the Clerk of Course role for the BLCC's inaugural Winter Classic Rally.

Ellis said the club had established a bench mark for Australia with the Winter Classic being the first event to be conducted under what were then new road touring regulations.

"Because the event has been organised in a rally format, not a treasure hunt, it has been welcomed by competitors," he said.

The event has attracted organisers of similar events from throughout Australia to watch and learn from Ballarat. "Classic rallies are a growing area of the sport because they don't require huge modifications to vehicles," Ellis said.

"It was a big learning experience

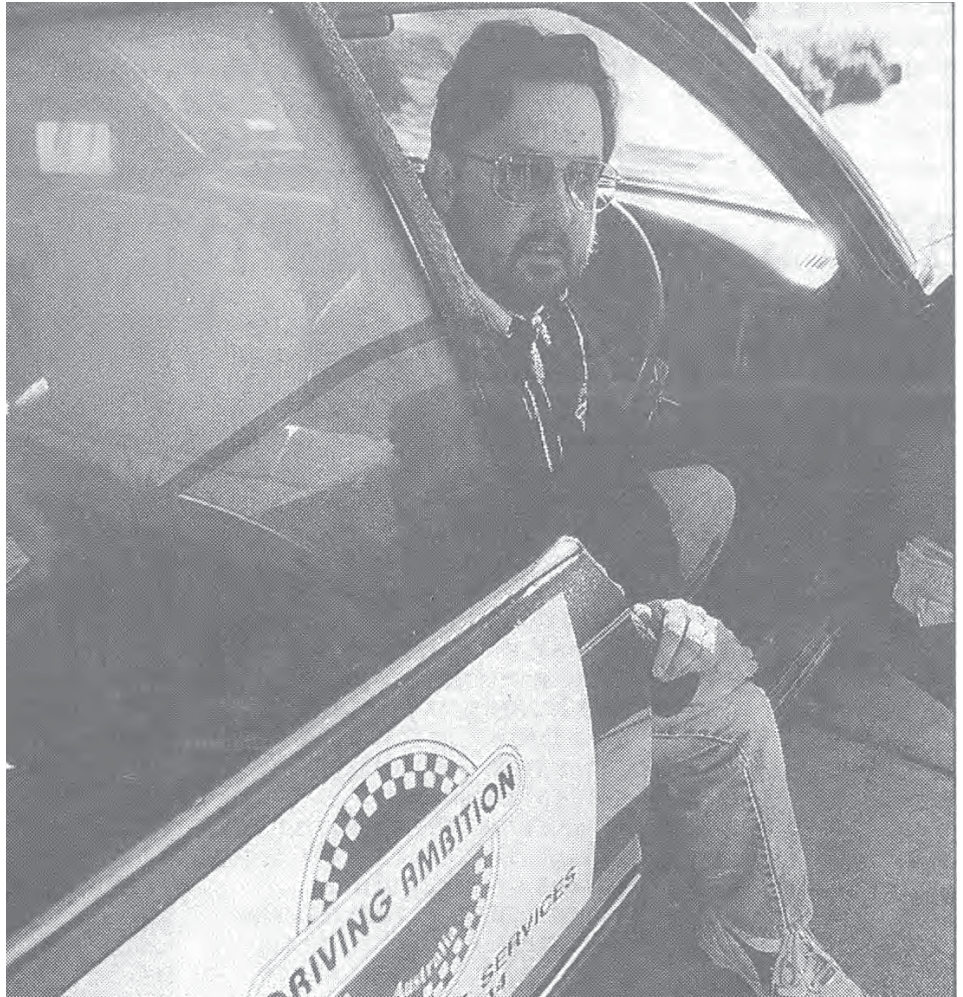

Ballarat Light Car Club Clubman of the year Peter Ellis is hooked on cars both as a hobby and a profession.

for all involved and the club hopes to establish it as an annual event."

This year the Winter Classic attracted 45 entries, predominantly from Victoria and South Australia, including motor-racing legend Norm Beechy in a 1995 Corvette and Winston Kim in a 1998 Ferrari F355.

The challenge of holding an event in winter included that of conducting all the road aspects in daylight and for that reason a maximum field of 65 cars had been set for the event.

"Competitors have already applied for next year and hopefully one day it might be difficult to get an entry to the event," Ellis said.

"We implemented a lot of competitor suggestions from 1997 event into 1998."

Ellis said he liked to see motor sport progress, particularly at a local level and his involvement helped make things happen.

Ellis did not compete during the last 12 months and believed it was the first time the clubman award had been won by someone who had not competed.

Ellis also does his bit to promote local motor sport through a radio show on Saturday morning.

His addiction to cars also flows through to Ellis's work as operator of Driving Ambition which caters for clients from 16 years to 74 years.



## E-mail Notifications.

**A** new e-mail notification system has been implemented on our site to simplify the process of keeping members and other interested parties informed of goings on in the club.

Sign up to receive event updates and announcements from Ballarat Light Car Club about upcoming events and activities. E-mail announcements will be sent out occasionally about website-related activities



and new website features.

Note: this feature is not in place of the electronic send out of the club newsletter. And all recipients of the bulletin should feel free to sign up for notifications.





# Ballarat Light Car Club

Incorporated (Certificate of Incorporation Number A20023019V)

## Application for Membership

P.O.Box 400 Ballarat, Vic, 3353

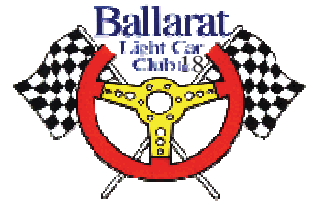

Dear Sir/Madam

I,  Mr  Mrs  Miss  Ms \_\_\_\_\_  
(Given Names in Full) (Surname)

of \_\_\_\_\_  
(Postal Address)

City/Town: \_\_\_\_\_ Postcode: \_\_\_\_\_

Telephones - Private: \_\_\_\_\_ Business: \_\_\_\_\_ Mobile: \_\_\_\_\_

Email Address: \_\_\_\_\_ @ \_\_\_\_\_ DOB: \_\_\_\_\_

desire an

**ORDINARY / JUNIOR / FAMILY / ASSOCIATE FAMILY / ASSOCIATE PARENT / ASSOCIATE COUPLE**  
membership of the Ballarat Light Car Club and agree, if elected, to be bound by the rules and bylaws of the club.  
( circle the applicable category of membership )

### Current Fees (01/07/05)

Category	Nomination	Annual
<b>Ordinary</b>	\$25.00	<b>\$90.00</b>
<b>Family</b>	\$25.00	<b>\$120.00</b> (2 Parents or Guardians, with any number of own children up to 17y.o or with appropriate dependent student ID)
<b>Associate Family</b>	nil	<b>\$83.00</b> ( 2 non-competing Adults, 1 competing child )
<b>Associate Parent</b>	nil	<b>\$58.00</b> (Parent/Guardian, 1 Child competing)
<b>Associate Couple</b>	nil	<b>\$50.00</b> (2 non competing adults)

Membership Type: \_\_\_\_\_ I enclose membership of \$ \_\_\_\_\_

Occupation / Employer: \_\_\_\_\_

Names of Family Members: Partner: \_\_\_\_\_ Child 1: \_\_\_\_\_ Child 2: \_\_\_\_\_

Child 3: \_\_\_\_\_ Child 4: \_\_\_\_\_

Type of vehicle/s that you will use to compete: Make: \_\_\_\_\_ Model: \_\_\_\_\_

I would like to receive my BULLETIN electronically at my email address above:

Signature: \_\_\_\_\_ Date: \_\_\_\_\_

**Please fill in all details and attach appropriate fees when submitting this form**

We, the undersigned, being members of the Ballarat Light Car Club, wish to recommend acceptance of the above application of the above application for membership. The above named candidate is personally known to us and we believe him/her to be a suitable person to be elected a member of the Ballarat Light Car Club Inc.

Proposer: \_\_\_\_\_ Signature: \_\_\_\_\_ Member No. \_\_\_\_\_

Seconder: \_\_\_\_\_ Signature: \_\_\_\_\_ Member No. \_\_\_\_\_

### Areas of Interest

Please tick if relevant boxes

#### Social

- Clubrooms
- Meetings
- Spectating
- Family Orientated Occasions
- Social Trips

#### Competition

- Circuit Racing
- Special Stage Rallies
- Trials
- Autocross
- Motokhana
- Hillclimb
- Sprints
- Off Road Racing
- Social Motoring / Touring
- Other (specify )

#### Officialling

- Rally / Trial controls
- Event Key Official
- Motorkhana
- Autocross
- Scrutiny
- Directing
- Fire/Rescue
- First Aid
- Flag Marshall
- Timing

#### Office Use Only

Received: / / 20

Fees \$.....

Received

Welcome Letter

Member Number .....

Completed



If undeliverable return to  
**Ballarat Light Car Club**  
PO Box 400  
Ballarat Vic 3353

**The Bulletin**

Print Post Approved

**PRINT  
POST**  
PP325876/00031

**POSTAGE  
PAID  
AUSTRALIA**

